

## FLIGHT MANUAL

### US-LSA



## P92 Echo Super

### Manufacturer

*COSTRUZIONI AERONAUTICHE TECNAM S.r.l.*

Type Certificate:     ASTM SLSA

Serial number: \_\_\_\_\_

Build year: \_\_\_\_\_

Registration: \_\_\_\_\_

#### **Introduction**

This manual contains information to be furnished to the pilot as required by the FAA in addition to further information supplied by the manufacturer.

This manual must always be present on board the aircraft.

The aircraft is to be operated in compliance with information and limitations contained herein. All sections follow the ASTM guidelines as finalized 1 April 2005.

### Record of Revisions

Any revisions to the present Manual, except actual weighing data, must be recorded in the following table. New or amended text in the revised pages will be indicated by a black vertical line in the left-hand margin; Revision Number, and date will be shown on the right-hand side of the amended page.

### Log of Revisions

Revision No.	Date released	Chapters	Approved By
1.0	03-30-2005	All	Tecnam
2.0	12-30-2006	All	Tecnam
2.01	01-22-2007	1	Tecnam
2.01a	02-24-2007	1	Tecnam
2.02	02-28-2007	6 (all)	Tecnam
2.03	04-11-2007	1	Tecnam
2.03a	05-24-2007	6	Tecnam
2.04	10-09-2007	All	Tecnam
3.00	10-29-2007	All	Tecnam
4.00	01-18-2008	All	Tecnam
5.00	08-05-2014	2, 3	Tecnam

### NOTE

Revision 3.00 updates all sections. Many corrections were grammatical. It is requested that all sections are reviewed for content change as well.

**List of Effective Pages**

Page	Date	Page	Date	Page	Date
1	01-18-2008	36	08-05-2014		
2	08-05-2014	37	01-18-2008		
3	08-05-2014	38	01-18-2008		
4	01-18-2008	39	01-18-2008		
5	01-18-2008	40	01-18-2008		
6	01-18-2008	41	01-18-2008		
7	01-18-2008	42	01-18-2008		
8	01-18-2008	43	01-18-2008		
9	01-18-2008	44	01-18-2008		
10	01-18-2008	45	01-18-2008		
11	01-18-2008	46	01-18-2008		
12	01-18-2008	47	01-18-2008		
13	01-18-2008	48	01-18-2008		
14	01-18-2008	49	01-18-2008		
15	01-18-2008	50	01-18-2008		
16	01-18-2008	51	01-18-2008		
17	01-18-2008	52	01-18-2008		
18	01-18-2008	53	01-18-2008		
19	01-18-2008	54	01-18-2008		
20	01-18-2008	55	01-18-2008		
21	01-18-2008	56	01-18-2008		
22	01-18-2008	57	01-18-2008		
23	01-18-2008	58	01-18-2008		
24	01-18-2008	59	01-18-2008		
25	01-18-2008	60	01-18-2008		
26	01-18-2008	61	01-18-2008		
27	01-18-2008	62	01-18-2008		
28	01-18-2008	63	01-18-2008		
29	08-05-2014	64	01-18-2008		
30	01-18-2008	65	01-18-2008		
31	01-18-2008	66	01-18-2008		
32	01-18-2008				
33	08-05-2014				
34	01-18-2008				
35	01-18-2008				

Unit Conversion Chart .....	10
<b>SECTION 1 GENERAL .....</b>	<b>11</b>
1.1 Introduction .....	11
1.2 Certification Basis .....	11
1.3 Descriptive Data .....	13
1.3.1 Airframe.....	13
1.4 Powerplant .....	13
1.4.1 Engine .....	13
1.4.2 Propeller .....	13
1.4.3 Oil System.....	14
1.4.4 Cooling.....	14
1.4.5 Fuel .....	14
1.5 Weights.....	14
1.5.1 Maximum Weights .....	14
1.5.2 Standard Weights .....	14
1.5.3 Specific Loadings.....	14
1.6 Standard Equipment.....	15
1.6.1 Flight Instruments .....	15
1.6.2 Engine instruments.....	15
1.6.3 Warning Lights and Indicators.....	15
1.6.4 Controls .....	15
1.6.5 Interior.....	15
1.6.6 Exterior .....	15
1.6.7 Powerplant and Accessories.....	15
1.7 Airframe.....	16
1.7.1 Wing .....	16
1.7.2 Fuselage.....	16
1.7.3 Empennage.....	16
1.7.4 Flight controls .....	16
1.7.5 Instrument Panel .....	17
1.7.6 Carburetor Heat (optional).....	17
1.7.7 Cabin Heat / Defrost.....	17
1.7.8 Throttle Friction Lock.....	17
1.7.9 Seats, Seatbelts, and Shoulder harnesses .....	17
1.7.10 Doors .....	18
1.7.11 Baggage compartment .....	18
1.8 Powerplant .....	18
1.8.1 Engine .....	18
1.8.2 Propeller .....	18
1.8.3 Fuel system.....	19
1.9 Electrical System.....	21

1.9.1	Generator light .....	21
1.9.2	Voltmeter .....	21
1.9.3	Oil temperature gauge .....	21
1.9.4	Cylinder head temperature .....	22
1.9.5	Oil Pressure.....	22
1.9.6	Fuel Pressure .....	22
1.9.7	O.A.T. Indicator (optional) .....	22
1.9.8	Stall Warning System (optional) .....	22
1.9.9	Avionics (optional).....	22
1.9.10	Exterior Lighting.....	22
1.10	<i>Pitot and Static Pressure Systems</i> .....	23
1.11	<i>Landing Gear</i> .....	24
1.11.1	Brake System .....	25
<b>SECTION 2 OPERATING LIMITATIONS .....</b>		<b>26</b>
<b>2</b>	<b>Introduction .....</b>	<b>26</b>
2.1.1	Airspeed Limitations .....	26
2.1.2	Airspeed Indicator Markings .....	26
2.1.3	Powerplant Limitations .....	27
2.1.4	Temperatures .....	27
2.1.5	Oil Pressure.....	27
2.1.6	Operating & starting temperature range .....	27
2.1.7	Fuel Pressure .....	27
2.1.8	Lubricant.....	28
2.1.9	Coolant .....	28
2.1.10	Propeller .....	28
2.1.11	Fuel .....	28
2.1.12	Approved Fuel .....	29
2.1.13	Powerplant Instrument Markings.....	29
2.1.14	Other Instrument Markings.....	29
2.1.15	Weights.....	29
2.1.16	Center of Gravity Limits.....	29
2.1.17	Approved Maneuvers .....	30
2.1.18	Maneuvering Load Factor Limits .....	30
2.1.19	Flight Crew .....	30
2.1.20	Kinds of Operations .....	30
2.1.21	Day VFR.....	30
2.1.22	Night .....	31
2.1.23	IFR.....	31
2.1.24	Demonstrated Crosswind Safe Operations .....	31
2.1.25	Service Ceiling.....	31
2.1.26	Limitation Placards .....	31
<b>3</b>	<b>Introduction .....</b>	<b>32</b>
3.1	<i>Aircraft weighing procedures</i> .....	32
3.1.1	Preparation.....	32
3.1.2	Calculate empty weight Weighing.....	32

3.1.3	Determination of C.G. location.....	32
3.2	<i>Weighing report</i> .....	33
3.2.1	Center of Gravity Limits .....	33
3.2.2	Distances from the datum .....	34
3.3	<i>Weight and Balance</i> .....	35
3.3.1	Loading .....	37
3.4	<i>Equipment List</i> .....	37
<b>SECTION 4 PERFORMANCE .....</b>		<b>40</b>
<b>4</b>	<b>Introduction .....</b>	<b>40</b>
4.1	<i>Use of Performance Charts</i> .....	40
4.2	<i>Airspeed Indicator System Calibration</i> .....	41
4.3	<i>ICAO Chart</i> .....	42
4.4	<i>Stall Speeds</i> .....	43
4.5	<i>Crosswind</i> .....	44
4.6	<i>Takeoff Performance</i> .....	45
4.7	<i>Landing Distance</i> .....	46
4.8	<i>Climb Performance</i> .....	47
4.9	<i>Cruise</i> .....	48
4.10	<i>Balked Landing</i> .....	49
4.11	<i>Effects of Rain and Insects</i> .....	49
4.12	<i>Noise Data</i> .....	49
<b>SECTION 5 EMERGENCY PROCEDURES.....</b>		<b>50</b>
<b>5</b>	<b>Introduction .....</b>	<b>50</b>
5.1	<i>Engine Failures</i> .....	51
5.1.1	Engine Failures on Ground .....	51
5.1.2	Engine Failure during Flight .....	51
5.2	<i>Smoke and Fire</i> .....	52
5.2.1	Engine Fire while parked .....	52
5.2.2	Engine Fire during Takeoff.....	52
5.2.3	Engine Fire in-flight.....	52
5.2.4	Cabin Fire during Flight.....	53
5.3	<i>Landing Emergency</i> .....	53
5.4	<i>Recovery from Unintentional Spin</i> .....	54
5.5	<i>Other Emergencies</i> .....	54
5.5.1	UNINTENTIONAL FLIGHT INTO ICING CONDITIONS.....	54
5.5.2	Carburetor Ice.....	54

5.6	<i>Electric Power System Malfunction</i> .....	55
5.6.1	GENERATOR LIGHT ILLUMINATES.....	55
5.7	<i>Trim System Failure</i> .....	55
5.7.1	LOCKED CONTROL .....	55
<b>SECTION 6 NORMAL PROCEDURES .....</b>		<b>56</b>
<b>6</b>	<b>Introduction .....</b>	<b>56</b>
6.1	<i>Removing and Reinstalling the Engine Cowling</i> .....	56
6.1.1	Upper Cowling .....	56
6.1.2	Lower Cowling .....	56
6.2	<i>Checklist Procedures</i> .....	57
6.2.1	Pre-Flight Inspection.....	57
<b>SECTION 7 GROUND HANDLING &amp; SERVICE .....</b>		<b>63</b>
<b>7</b>	<b>Introduction .....</b>	<b>63</b>
7.1	<i>Aircraft Inspection Periods</i> .....	63
7.2	<i>Aircraft Alterations or Repairs</i> .....	63
7.3	<i>Ground Handling</i> .....	63
7.3.1	Towing .....	63
7.3.2	Parking and Tiedown .....	63
7.3.3	Jacking .....	63
7.3.4	Leveling.....	63
7.3.5	Road Transport .....	63
7.3.6	Cleaning and Care .....	64
<b>8</b>	<b>Placards and Markings.....</b>	<b>65</b>

### WARNINGS - CAUTIONS - NOTES

The following definitions apply to warnings, cautions and notes used in the Flight Manual.

#### WARNING

Means that the non-observation of the corresponding procedure leads to an immediate or important degradation of the flight safety

#### CAUTION

Means that the non-observation of the corresponding procedure leads to a minor or to a more or less long-term degradation of the flight safety

#### NOTE

Draws the attention to any special item not directly related to safety but which is important or unusual.

### Abbreviations & Terminology

#### Airspeed Terminology

KCAS	Calibrated Airspeed is the indicated airspeed corrected for position and instrument error and expressed in knots.
KIAS	Indicated Airspeed is the speed shown on the airspeed indicator and expressed in knots.
KTAS	True Airspeed is the airspeed expressed in knots relative to undisturbed air, which is KCAS, corrected for altitude and temperature.
V <sub>A</sub>	Design maneuvering speed
V <sub>C</sub>	Design cruising speed
V <sub>FE</sub>	Maximum Flap Extended Speed is the highest speed permissible with wing flaps in a prescribed extended position.
V <sub>H</sub>	Max Speed in level flight with Max continuous power
V <sub>LO</sub>	Lift off speed: is the speed at which the aircraft generally lifts off from the ground.
V <sub>NE</sub>	Never Exceed Speed is the speed limit that may not be exceeded at any time.
V <sub>NO</sub>	Maximum Structural Cruising Speed is the speed that should not be exceeded except in smooth air, then only with caution.
V <sub>S</sub>	Stalling Speed or minimum steady flight speed flaps retracted
V <sub>S0</sub>	Stalling speed or minimum steady flight speed in landing configuration
V <sub>S1</sub>	Stalling speed in clean configuration (flap 0°)
V <sub>X</sub>	Best Angle-of-Climb Speed is the speed, which results in the greatest gain of altitude in a given horizontal distance.
V <sub>Y</sub>	Best Rate-of-Climb Speed is the speed, which results in the greatest gain in altitude in a given time.
V <sub>R</sub>	Rotation speed: is the speed at which the aircraft rotates about the pitch axis during takeoff.

#### Meteorology Terminology

OAT	Outside Air Temperature is the free air static temperature expressed in degrees Celsius (°C).
T <sub>S</sub>	Standard Temperature is 15°C (59°F) at sea level pressure altitude and decreased by 2°C for each 1000 ft of altitude.
H <sub>P</sub>	Pressure Altitude is the altitude read from an altimeter when the barometric subscale has been set to 29.92"

#### Engine Power Terminology

RPM	Revolutions Per Minute: is the number of revolutions per minute of the propeller, multiplied by 2.4286 yields engine RPM.
-----	---



### Airplane Performance and Flight Planning Terminology

Crosswind Velocity	is the velocity of the crosswind component for which adequate control of the airplane during takeoff and landing is guaranteed
Usable fuel	is the fuel available for flight planning
Unusable fuel	is the quantity of fuel that cannot be safely used in flight
g	is the acceleration of gravity
TOR	is the takeoff distance measured from actual start to wheel lift off point
TOD	is total takeoff distance measured from start to clearing a 50' obstacle
GR	is the distance measured during landing from actual touchdown to stop point
LD	is the distance measured during landing, from clearing a 50' obstacle to actual stop
S/R	is specific range, that is, the distance (in nautical miles) which can be expected at a specific power setting and/or flight configuration per gallon of fuel used

### Weight and Balance Terminology

Datum	“Reference datum” is an imaginary vertical plane from which all horizontal distances are measured for balance purposes
Arm	is the horizontal distance from the reference datum to the center of gravity (C.G.) of an item
Moment	is the product of the weight of an item multiplied by its arm
C.G.	Center of Gravity is the point at which the airplane, or equipment, would balance if suspended. Its distance from the reference datum is found by dividing the total moment by the total weight of the airplane
Empty Weight	Empty Weight is the weight of the airplane with engine fluids and oil at operating levels
Useful Load	is the difference between takeoff weight and the empty weight
Maximum Takeoff Weight	is the maximum weight approved for the start of the takeoff run
Maximum Landing Weight	is the maximum weight approved for the landing touch down
Tare	is the weight of chocks, blocks, stands, etc. used when weighing an airplane, and is included in the scale readings; tare is then deducted from the scale reading to obtain the actual (net) airplane weight

**Unit Conversion Chart**

Multiplying		by →	yields	
<b>Temperature</b>				
Fahrenheit	[°F]	$\frac{5}{9} \cdot (F - 32)$	Celsius	[°C]
Celsius	[°C]	$\left(\frac{9}{5} \cdot C\right) + 32$	Fahrenheit	[°F]
<b>Forces</b>				
Kilograms	[kg]	2.205	Pounds	[lbs]
Pounds	[lbs]	0.4536	Kilograms	[kg]
<b>Speed</b>				
Meters per second	[m/s]	196.86	Feet per minute	[ft/min]
Feet per minute	[ft/min]	0.00508	Meters per second.	[m/s]
Knots	[kts]	1.853	Kilometers / hour	[km/h]
Kilometers / hour	[km/h]	0.5396	Knots	[kts]
<b>Pressure</b>				
Atmosphere	[atm]	14.7	Pounds / sq. in	[psi]
Pounds / sq. in	[psi]	0.068	Atmosphere	[atm]
<b>Length</b>				
Kilometers	[km]	0.5396	Nautical miles	[nm]
Nautical miles	[nm]	1.853	Kilometers	[km]
Meters	[m]	3.281	Feet	[ft]
Feet	[ft]	0.3048	Meters	[m]
Centimeters	[cm]	0.3937	Inches	[in]
Inches	[in]	2.540	Centimeters	[cm]
<b>Volume</b>				
Liters	[l]	0.2642	U.S. Gallons	[US Gal]
U.S. Gallons	[US Gal]	3.785	Liters	[l]
<b>Area</b>				
Square meters	[m <sup>2</sup> ]	10.76	Square feet	[sq ft]
Square feet	[sq ft]	0.0929	Square meters	[m <sup>2</sup> ]
<b>Torque</b>				
foot-pounds		1.3558	Newton-meters	
foot-pounds		0.1383	kilogram-meters	
foot-pounds		12.0	inch-pounds	
inch-pounds		0.0115	kilogram-meters	
inch-pounds		0.1130	Newton-meters	
inch-pounds		0.0833	foot-pounds	
kilogram-meters		7.233	foot-pounds	
kilogram-meters		86.7964	inch-pounds	
kilogram-meters		9.8067	Newton-meters	
Newton-meters		0.7376	foot-pounds	
Newton-meters		8.8508	inch-pounds	
Newton-meters		0.1020	kilogram-meter	

## **SECTION 1**

### **GENERAL**

#### **1.1 Introduction**

The P92 Echo Super is an all metal, high wing, two-place, single-engine airplane equipped with tricycle landing gear. It is an ASTM compliant airplane designed to be flown by sport pilot rated pilots as well as higher rated pilots.

This aircraft is designed and built in Italy and as such, was built using the metric system. Therefore, the primary numbers are in metric and the US conversion is in parenthesis for your information.

This Flight Manual has been prepared to ASTM standards to provide pilots and instructors with information for the safe and efficient operation of this aircraft.

This Flight Manual contains the following sections:

1. General Information
2. Operating Limitations
3. Weight & Balance
4. Performance
5. Emergency Procedures
6. Normal Procedures
7. Aircraft Ground Handling and Servicing
8. Required Placards and Markings

#### **1.2 Certification Basis**

This aircraft is certificated as a Special Light Sport Aircraft under FAR part 21.190 and complies with all applicable ASTM standards.

# P92 Echo Super Flight Manual

## THREE VIEW DRAWING

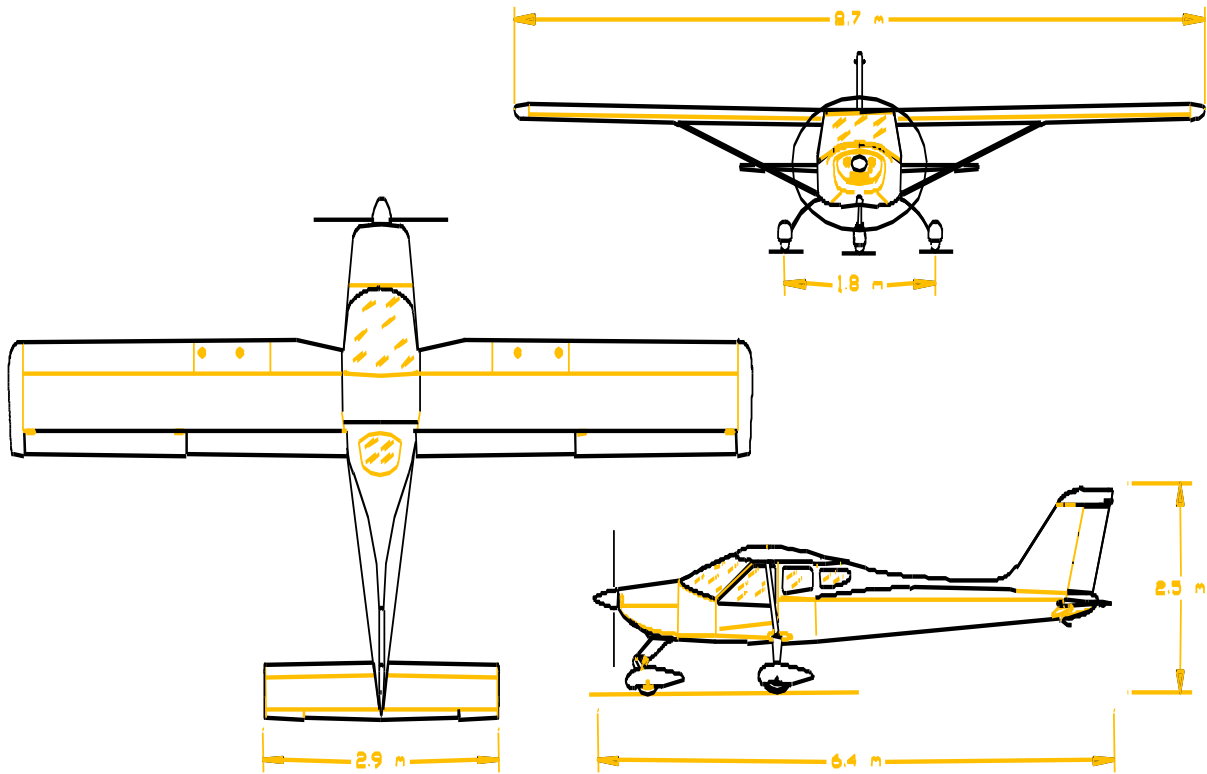

Figure 1-1 General Views

Wing Span	8.7m (28.54')
Length	6.4m (21')
Tail height	2.5m (8.2')
Propeller ground clearance	320mm (12.6")
Minimum ground steering radius	5.5m (18')

**NOTE**

- Dimensions shown refer to aircraft weight of 600 kg (1320 lbs) and normal operating tire pressure

## 1.3 Descriptive Data

### 1.3.1 Airframe

#### 1.3.1.1 Wing

Wing span	8.70 m (28.54')
Wing area	12 m <sup>2</sup> (129 sq ft)
Aspect ratio	6.30
Taper ratio	1.00
Dihedral	1.5°
Wing chord	1.400 m (4.6')

#### 1.3.1.2 Fuselage

Overall length	6.4 m (21')
Overall width	1.1 m (43")
Overall height	2.5 m (8.2')

#### 1.3.1.3 Empennage

Stabilator span	2.9 m (9.5')
Stabilator area	1.972 m <sup>2</sup> (21.2 ft <sup>2</sup> )

#### 1.3.1.4 Landing Gear

Wheel track	1.8 m (5.9')
Wheel base	1.6 m (5.2')
Main gear tires	Air Trac 5.00-5
Nose gear tire	Sava 4.00-6
Wheel brakes	Marc Ingegno 199-102

## 1.4 Powerplant

### 1.4.1 Engine

Manufacturer	Bombardier-Rotax GmbH
Model	912 ULS or 912 S2
Certification basis	ASTM F2239 or FAR Part 33
Type	4 stroke carburetor engine
Maximum power	73.5 kW (98.5 hp) @ 5800 rpm (max. 5 minutes) 69.0 kW (92.5 hp) @ 5500 rpm (cont.)

### 1.4.2 Propeller

Manufacturer	GT Tonini
Model	GT-2/173/VRR- FW101 SRTC
Number of blades	2
Diameter	1730 mm (68") (no reduction permitted)
Type	Fixed pitch – wood / composite

### 1.4.3 Oil System

Oil system	Forced, with external oil reservoir
Oil	See Rotax operator's manual
Oil Capacity	Max. 3.0 liters (3.2 qt) – min. 2.0 liters (2.1 qt)

### 1.4.4 Cooling

Cooling system:	Combination air and liquid cooled system
Coolant:	See Rotax operator's manual
Capacity	3.0 liters (3.17 quarts)

### 1.4.5 Fuel

<u>Fuel grade:</u>	
Auto fuel	Min. RON 95 (AKI 91 Premium USA)
Avgas	100LL
Fuel tanks	2 integral wing tanks
Capacity of each wing tank	35 liters (9.2 gal) (optional 45 liters) (11.9 gal)
Total capacity	70 liters (18.49 gal) (optional 90 liters) (23.8 gal)
Total usable fuel	66.8 liters. (17.64 gal) (86.8 liters) (22.93 gal)

## 1.5 Weights

### 1.5.1 Maximum Weights

Maximum take-off weight:	600 kg (1320 lbs)
Maximum landing weight:	600 kg (1320 lbs)
Maximum baggage weight	20 kg (44 lbs)

### 1.5.2 Standard Weights

Empty weight	325 kg (716 lb)
Maximum payload weight	275 kg (604 lb)

### 1.5.3 Specific Loadings

Wing Loading	50 kg/m <sup>2</sup> (10.2 lb/ft <sup>2</sup> )
Power Loading	6 kg/hp (13.2 lb/hp)

#### NOTE

Standard weights are estimates based on standard equipment.

## 1.6 Standard Equipment

<b>1.6.1 Flight Instruments</b>
Airspeed Indicator, Altimeter, Vertical Speed Indicator, Compass
<b>1.6.2 Engine instruments</b>
Tachometer, Oil Pressure, Fuel Pressure, Oil Temperature, Cylinder Head Temperature, Hour Meter, Left and Right Fuel Quantity, Volt Meter
<b>1.6.3 Warning Lights and Indicators</b>
Trim Indicator, Flap Indicator, Generator Warning Light
<b>1.6.4 Controls</b>
Dual Stick Flight Controls and Rudder Pedals, Dual Throttles, Throttle Friction Control, Engine Choke, Electric Flaps, Hydraulic Disc Brakes with Parking Brake, Left and Right Fuel Selector Valves, Direct Nose Wheel Steering
<b>1.6.5 Interior</b>
Adjustable Pilot and Copilot Seats, Acoustic Cabin Soundproofing, Adjustable Cabin Air Ventilators, Steel Roll Cage, Cabin Heat and Windshield Defrost, 12V Power Outlet, Metal Instrument Panel
<b>1.6.6 Exterior</b>
All Aluminum structure, Landing Light, Strobe Light, Fixed Landing Gear, Nose Gear Strut Fairing, Nose and Main Wheel Fairings
<b>1.6.7 Powerplant and Accessories</b>
Rotax 912 ULS Engine (100 hp), Composite Covered Wood Propeller with Spinner, 12Volt 18 Ah Battery, 18 Amp Alternator, Engine Driven Fuel Pump, Electric Starter, Engine Exhaust Muffler, Gascolator with Quick Drain, Integral Wing Fuel Tanks, All Electric Circuits Fuse Protected

## **1.7 Airframe**

### **1.7.1 Wing**

The wing is constructed of a central light alloy torque box; an aluminum leading edge with integrated fuel tank is attached to the front spar while flap and aileron are hinged to rear spar. Flaps are constructed of a center spar to which front and rear ribs are joined; wrap-around aluminum skin panels cover the flap structure. The aileron is constructed of an aluminum spar to which a formed sheet metal leading edge and metal ribs are attached; a wrap-around, thermosetting synthetic material covers aileron structure.

### **1.7.2 Fuselage**

The front part of the fuselage is made up of a mixed structure: a truss structure with special steel members for cabin survival cell, and a light-alloy semi-monocoque structure for the cabin's bottom section. The aft part of the fuselage is constructed of an aluminum alloy semi-monocoque structure. The engine housing is isolated from the cabin by a stainless steel firewall; the steel stringers engine mount is attached to the cabin's truss structure in four points.

### **1.7.3 Empennage**

The vertical tail is entirely metal: the vertical stabilizer is made up of a twin spar with load carrying skin while the rudder consists of an aluminum torque stringer connected to light alloy ribs and skin. The horizontal tail is an all-moving type (stabilator); its structure consists of an aluminum tubular spar connected to ribs and leading edge; the entire structure is covered with thermo retractable synthetic material or aluminum.

### **1.7.4 Flight controls**

The control surfaces are manually operated using a control stick for ailerons and stabilator and rudder pedals for the rudder; longitudinal control acts through a system of push-rods and is equipped with a trim tab. Aileron control is of mixed type with push-rods and cables; the cable control circuit is confined within the cabin and is connected to a pair of push-rods positioned in the wings that control ailerons differentially. Aileron trimming is carried out on ground through a small tab positioned on left aileron.

Flaps are extended via an electric servo actuator controlled by a switch on the control stick. Flaps act in a continuous mode; a panel mounted indicator shows surface position. A fuse positioned on the right side of the panel protects the electric circuit.

Longitudinal trim is performed by a small tab positioned on the stabilator and controlled via an electric servo actuator by pushing an Up/Down push-button located on the control stick.



### 1.7.5 Instrument Panel

The instrument panel is of conventional type, allowing space for a broad range of equipment.

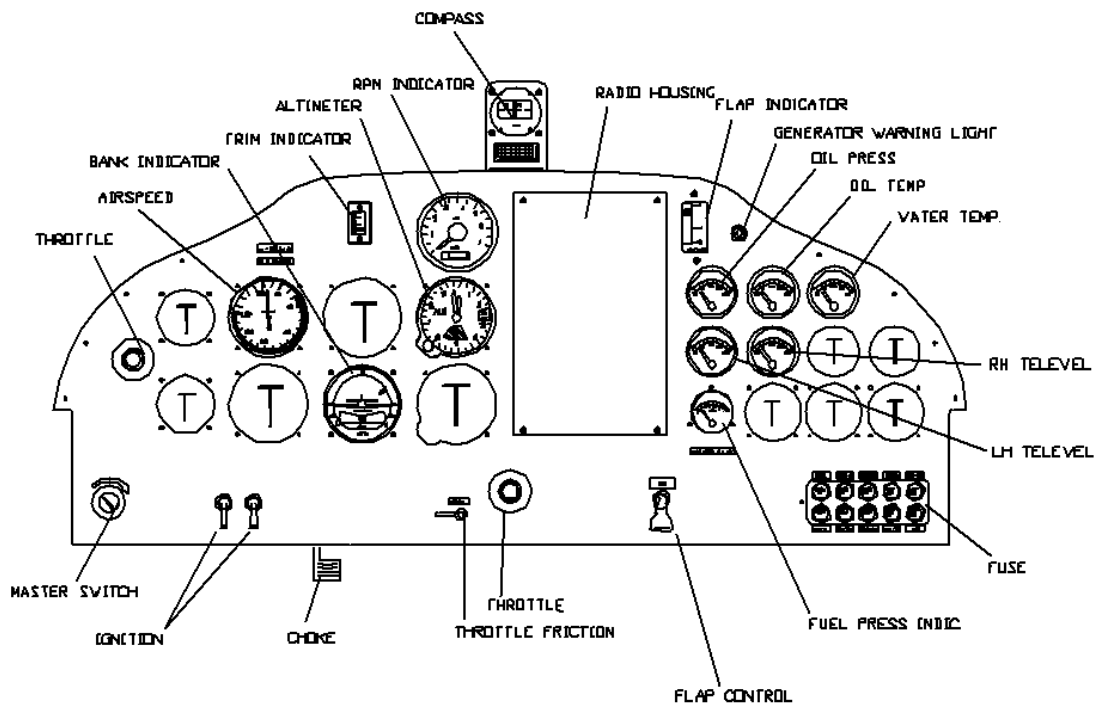

Fig. 1-2 Instrument Panel

### 1.7.6 Carburetor Heat (optional)

Carburetor heat control knob is located just to the right of the center throttle control. When the knob is pulled fully outward from the instrument panel, carburetors receive maximum hot air. During normal operation, the knob is OFF.

### 1.7.7 Cabin Heat / Defrost

The cabin heat control knob is positioned on the lower left side of the instrument panel; when knob is pulled fully outward, cabin receives maximum hot air. Vents are located by the rudder pedals and above instrument panel. If necessary, outside fresh air can be circulated inside cabin by opening the vents on the panel.

### 1.7.8 Throttle Friction Lock

Adjust the engine's throttle friction by tightening or loosening the friction lock located on the panel near center throttle control.

### 1.7.9 Seats, Seatbelts, and Shoulder harnesses

The P92 usually comes with three point safety belts with waist and diagonal straps adjustable via a sliding metal buckle. Optional four point harnesses are available.

Standard seats are aluminum with cushions. Seats are adjustable fore and aft by using the handle located under the seat on the outboard sides. Pushing the lever towards the center of the aircraft will release the locking pin allowing you to move the seat fore and aft. Release the lever when the desired position is found making sure that the locking pin reengages in the seat track.

#### WARNING

Make sure that the locking pin is securely installed or the seat will not lock in position.

### 1.7.10 Doors

Standard doors feature a light alloy tubular frame supporting a clear or tinted window. An internal safety latch mechanism is positioned in proximity of door's upper edge and must be used before flight to secure door. Mechanism rotates, before flight, to engage doorframe to cabin tubular framework.

### 1.7.11 Baggage compartment

The baggage compartment is located behind the seats. Baggage shall be uniformly distributed and its weight shall not exceed 20 kg (44 lbs) and the c.g. must be computed before flight. Always tie down the baggage by using the adjustable tie-down net provided.

## 1.8 Powerplant

### 1.8.1 Engine

Rotax is an Austrian engine manufacturer, founded in 1920 in Dresden, Germany. In 1970 Bombardier bought Rotax. The company constructed only two-stroke engines until 1982, when it started building four-stroke engines. In 1989, Rotax received Type Certification for its 912 A aircraft engine.

The Rotax 912 ULS engine is an ASTM compliant engine. The 912 is a four stroke, horizontally opposed, spark ignition engine with single central camshaft with hydraulic tappets. The 912 has liquid cooled cylinder heads and ram air cooled cylinders and engine. It is rated at 5800 RPM and can be run continuously at 5500 RPM.

The oil system is a dry sump, forced lubrications system. The oil tank is located on the passenger side of the engine compartment and holds 3 liters (3.2 quarts) of oil.

The dual ignition system is a solid state, breakerless, capacitive discharge, interference suppression system instead of a mechanical magneto system. Each ignition system is powered by individual and totally independent AC generators which are not dependent on the aircraft battery.

The electrical system consists of an integrated AC generator with an external rectifier – regulator. An optional external alternator can be installed. The Rotax engine is equipped with an electric starter.

The dual carburetors are constant depression carburetors that automatically adjust for altitude.

The fuel system is equipped with an engine driven mechanical pump.

The cooling system is a mixture of liquid and air cooling.

The engine uses a reduction gearbox with a gear reduction ratio of 2.4286:1.

Two throttles in the cockpit control the engine. The throttles are bussed together and will not move independently. The two throttles are installed to allow the pilot to fly with either hand as well as giving the pilot the option of using the left hand throttle while operating the center mounted brake handle.

The owner can register and get important information from the following website: <http://www.rotax-owner.com/>.

### 1.8.2 Propeller

The GT propeller is a wood composite propeller built by GT Tonini in Italy. The Tonini brothers began building propellers in 1969.

The propeller is finished with a white polyurethane lacquer and an additional layer of transparent lacquer. The tips are painted in bright yellow and red so that when the propeller is turning it is obvious to personnel on the ground. The back of the propeller is painted black to prevent reflections. More information on the company and the propeller can be found at <http://www.gt-propellers.com>. Check with your dealer for propeller options.

**1.8.3 Fuel system**

The system is equipped with two aluminum fuel tanks integrated within the wing leading edge and accessible for inspection through dedicated covers. Capacity of individual tank is 35lt (9.2 gal) (45lt optional / 11.9 gal) and total usable fuel is 66.8lt (17.6 gal) (86.8lt / 23.0 gal). Each fuel tank is equipped with a cabin installed shutoff valve. A strainer cup with a drainage valve (Gascolator) is located on the engine side of the firewall. Fuel level indicators for each tank are located on instrument panel. Fuel feed is through an engine-driven mechanical pump. All fuel lines located in the engine compartment are protected with fireproof braiding to avoid possible fire. Figure 1-3 illustrates the schematic of the fuel system.

**WARNING**

Fuel quantity should be checked on a level surface or a false reading may result. Always visually verify fuel quantity by looking in the tanks.

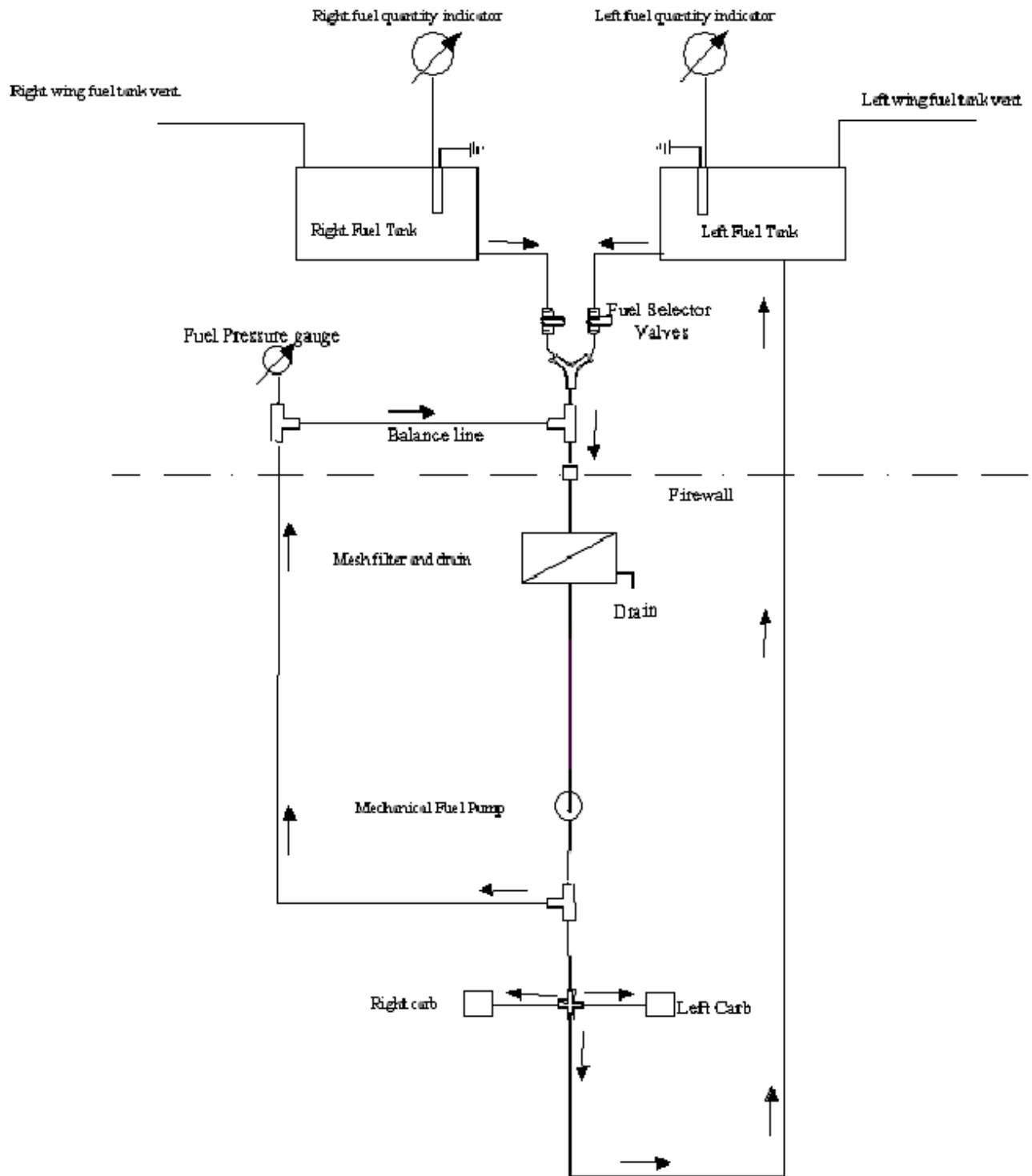

Figure 1-3 Fuel System

## 1.9 Electrical System

The aircraft's electrical system consists of a 12 Volt DC circuit controlled by a Master switch located on the instrument panel. An integrated AC generator provides electricity and a 12 Volt battery placed in the fuselage or in the engine compartment. The generator light is located on the right side of the instrument panel.

### WARNING

If the Ignition Switches are ON, an accidental movement of the propeller may start the engine with possible danger for bystanders.

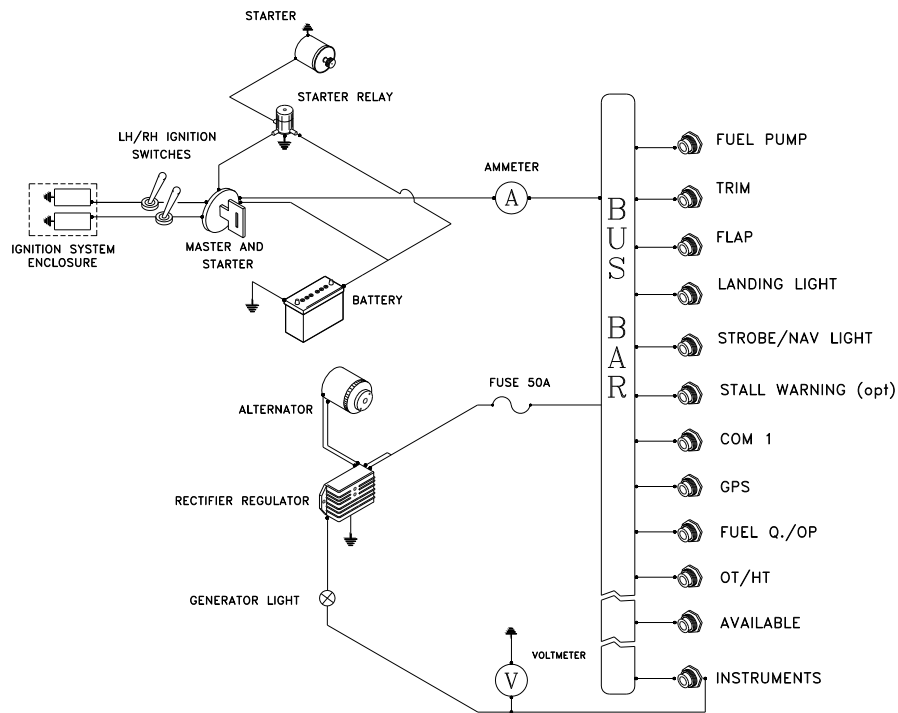

Fig.1-4 Electrical system schematic

### 1.9.1 Generator light

Generator light (red) illuminates for the following conditions:

- Generator failure
- Failure of regulator/rectifier, with consequent over voltage sensor set off

#### NOTE

The battery can support energy requirements for approximately 20 minutes.

### 1.9.2 Voltmeter

The voltmeter indicates voltage on the bus bar. The normal range is from 12 to 14 volts. There is a red radial line at 10 volts.

### 1.9.3 Oil temperature gauge

Temperature reads in degrees Celsius. The oil temperature gauge has a green normal operating range, yellow caution ranges, and two red lines.

#### **1.9.4 Cylinder head temperature**

The cylinder head temperature gauge normally reads the number three cylinder head temperature. It also indirectly reflects the coolant temperature. The cylinder head temperature reads in degrees Celsius.

#### **NOTE**

The same fuse protects all temperature instruments.

#### **1.9.5 Oil Pressure**

The oil pressure gauge is electric and is protected by a fuse. It reads in bars and has a green normal operating range, yellow caution ranges, and two red lines.

#### **1.9.6 Fuel Pressure**

Fuel pressure is calibrated in bars. It is directly connected to the fuel system and is not electric.

#### **NOTE**

One bar is equal to about 14.7 pounds of pressure

#### **1.9.7 O.A.T. Indicator (optional)**

A digital Outside Air Temperature indicator (°C) is located on the upper left side of the instrument panel. The sensor is placed on cabin top.

#### **1.9.8 Stall Warning System (optional)**

The aircraft may be equipped with a stall warning system consisting of a sensor located on the right wing leading edge connected to a warning horn located on the instrument panel.

#### **1.9.9 Avionics (optional)**

The central part of the instrument panel holds room for avionics equipment. The manufacturer of each individual system furnishes features for each system.

#### **1.9.10 Exterior Lighting**

Typical exterior lighting consists of:

- Landing light
- Tail Strobe Light
- Navigation lights (optional)
- Wing Strobe Lights (optional)

##### **1.9.10.1 Navigation Lights (Optional)**

Navigation lights are installed on the wing tips and on top of vertical stabilizer. A single switch located on instrument panel controls all navigation lights. A fuse protects the lights.

A green light is located on right wing tip; a red light on left wing tip and a white lamp is on vertical stabilizer.

##### **1.9.10.2 Landing Light**

The landing light is located on the LH wing leading edge. Landing light switch is located on instrument panel. Light is protected by a 10 Amp fuse.

##### **1.9.10.3 Tail Strobe Light**

The strobe light is installed on top of the vertical stabilizer.

Strobe light is activated by a switch and is protected by a fuse. Switch and fuse are positioned on the instrument panel. The signal reaches a strobe light trigger circuit box positioned in the tail cone just behind the baggage compartment.

## 1.10 Pitot and Static Pressure Systems

The airspeed indicator system for the aircraft is shown below.

Below the left wing's leading edge the Pitot tube (1) while on the fuselage's sides there are two static ports (2). Two flexible hoses (3) feed the airspeed indicator (4), the altimeter (5) and the VSI (6) on the instrument panel.

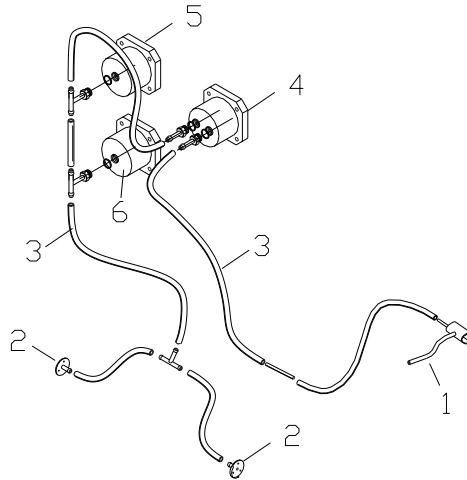

Fig.1-5 Pitot Static system

### 1.11 Landing Gear

The main landing gear consists of two special steel spring-leaf struts (1) positioned crossways to fuselage for elastic cushioning of landing loads.

The two steel spring-leaf struts are attached to the fuselage underside via the main girder.

Two rawhide liners (2 3) are inserted between each spring-leaf and the girder. Two bolts (5) and nuts secure the individual spring-leaf to the edge of the girder via a light alloy clamp (4) while a single bolt (6) and nut secures the inboard end of the leaf-spring to the girder.

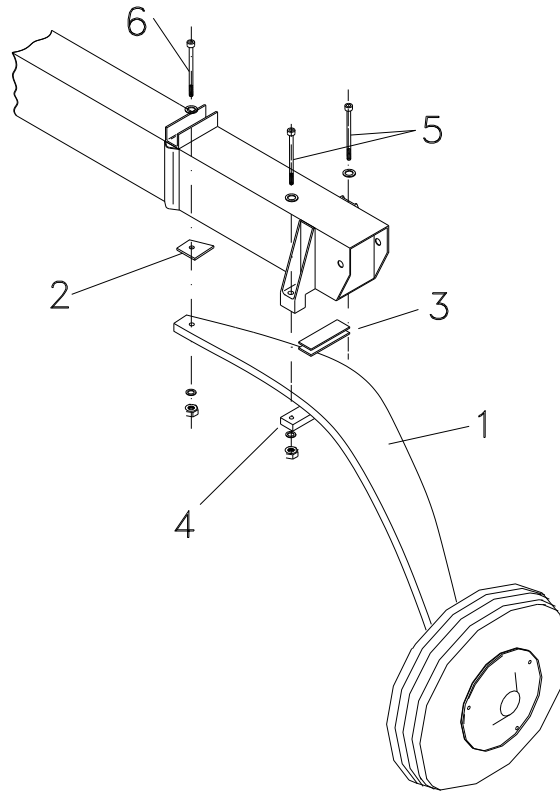

Figure 1-6 Main landing gear

Wheels are cantilevered on gear struts and feature hydraulically actuated disc brakes (see fig. 4-13) controlled by a lever (1) located on cabin tunnel between seats. Main gear wheels mount Air-Trac type 5.00-5 tires inflated at 23 PSI (1.6 bar). Hydraulic circuit shut-off valve (2) is positioned between seats. With circuit shut off, pulling emergency brake lever activates parking brake function.

Braking is simultaneous on both wheels via a “T” shaped joint (6).

Control lever (1) activates master cylinder (3) that features built-in brake-fluid reservoir (4). The brake system is equipped with a non-return valve (5), which insures that braking action is always effective even if parking brake circuit should accidentally be closed.



### 1.11.1 Brake System

The aircraft's brake system is a single-system acting on both wheels of the main landing gear through disk brakes. The same circuit acts as a parking brake by setting the parking brake.

To activate brakes verify that the brake shut-off valve positioned on tunnel between pilots is OFF, then activate brake lever as necessary. Pull brake lever and set the brake shut-valve to ON to activate parking brake.

The reservoir tank is located under the pilot's seat.

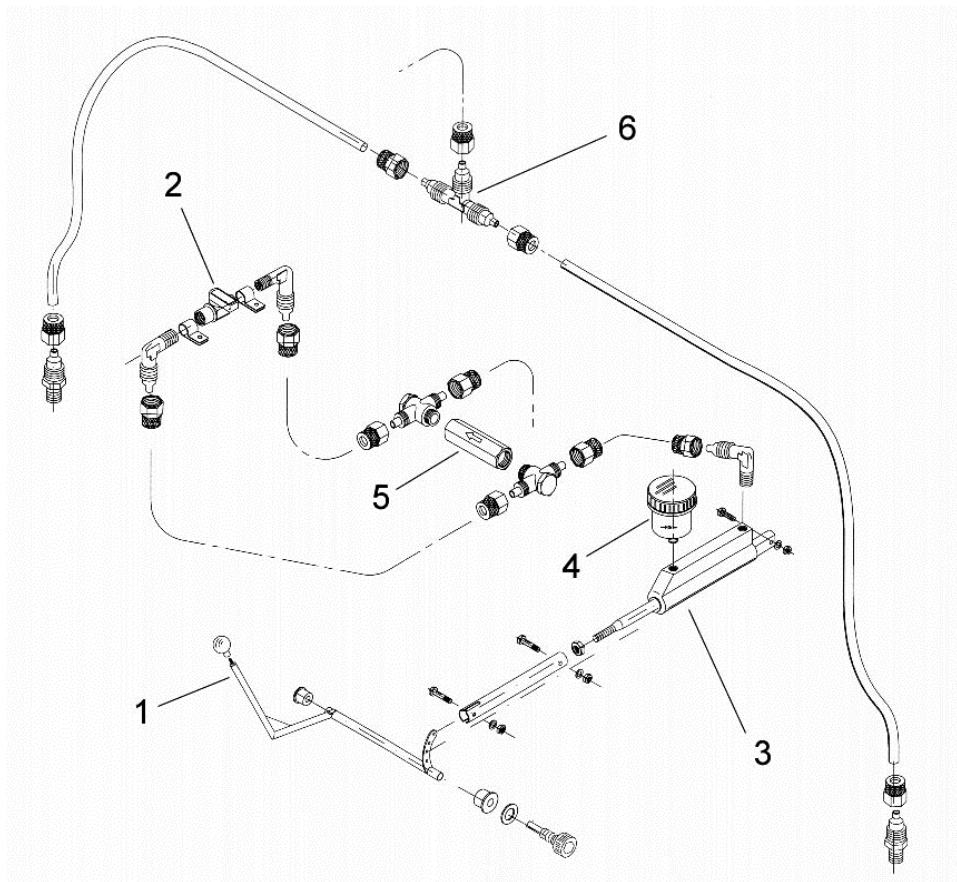

Fig. 1-7 Brake System

## SECTION 2 OPERATING LIMITATIONS

### 2 Introduction

Section 3 includes operating limitations, instrument markings, and basic placards necessary for safe operation of the P92 Echo Super, its engine, standard systems and standard equipment.

#### 2.1.1 Airspeed Limitations

Airspeed limitations and their operational significance are shown below:

SPEED		KCAS	KIAS	REMARKS
V <sub>NE</sub>	Never exceed speed	127	134	Never exceed this speed in any operation
V <sub>NO</sub>	Maximum Structural Cruising Speed	101	106	Never exceed this speed unless in smooth air, and then only with caution
V <sub>A</sub>	Maneuvering speed	88	93	Do not make full or abrupt control movements above this speed as this may cause stress in excess of limit load factor
V <sub>FE</sub>	Maximum flap extended speed	66	68	Never exceed this speed for any given flap setting
V <sub>H</sub>	Maximum speed	115	120	Maximum speed in level flight at max continuous power (MSL)
V <sub>X</sub>	Best Angle Climb	58	60	The speed which results in the greatest gain of altitude in a given horizontal distance
V <sub>Y</sub>	Best Rate Climb	66	68	The speed which results in the greatest gain of altitude in a given time

#### Airspeed Indicator Markings

Airspeed indicator markings and their color code are explained in the following table:

MARKING	KIAS	SIGNIFICANCE
White arc	43 – 68	Flap Operating Range (lower limit is 1.1 V <sub>SO</sub> , at maximum weight and upper limit is maximum speed permissible with full flaps)
Green arc	48 – 106	Normal Operating Range (lower limit is 1.1 V <sub>S1</sub> at maximum weight and flaps at 0° and upper limit is maximum structural speed V <sub>NO</sub> )
Yellow arc	106 – 134	Operations must be conducted with caution and only in smooth air
Red line	134	Maximum speed for all operations

### 2.1.2 Powerplant Limitations

The following table lists operating limitations for aircraft installed engine:

Engine manufacturer: Bombardier Rotax GmbH.

Engine model: 912 ULS or S2

Maximum power: (see table below)

	Max Power kW (hp)	Max rpm. rpm prop.(engine)	Time max. (min)
Max.	73.5 (98.5)	2388 (5800)	5
Max cont.	69 (92.5)	2265 (5500)	-

#### NOTE

Static engine rpm should be  $5100 \pm 250$  under no wind conditions.

### 2.1.3 Temperatures

Max cylinder heads	135° C
Max coolant	120° C
Max. / min. Oil	50° C / 130° C
Oil normal operating temperature (approx.)	90° C – 110° C

### 2.1.4 Oil Pressure

Minimum	0.8 bar	Below 3500 RPM
Normal	2.0 - 5.0 bar	Above 3500 RPM

### 2.1.5 Operating & starting temperature range

OAT Min	-25° C
OAT Max	+50° C

#### Warning

Admissible pressure for cold start is 7 bar maximum for short periods.

#### *For your information*

Bar is a unit of measure. The word comes from the Greek baros, "weighty." We see the same root in our word, barometer, for an instrument measuring atmospheric pressure. One bar is just a bit less than the average pressure of the Earth's atmosphere, which is 1013.25 bar. In practice, meteorologists generally record atmospheric pressure in millibars (mb). In English-speaking countries, barometric pressure is also expressed as the height, in inches, of a column of mercury supported by the pressure of the atmosphere. In this unit, one bar equals 29.53 inches of mercury (in Hg) or 14.5 PSI.

### 2.1.6 Fuel Pressure

Min	0.15 bar (2.2 PSI)
Max	0.40 bar (5.8 PSI)

### 2.1.7 Lubricant

Viscosity

Use viscosity grade oil as specified in the following table:

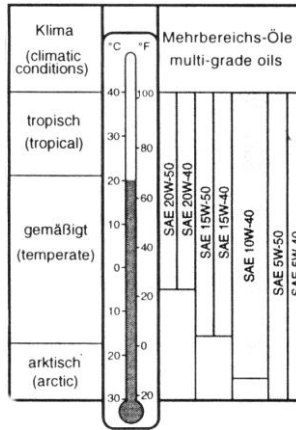

#### Warning

Admissible pressure for cold start is 7 bar maximum for short periods

#### Warning

Use of Aviation Grade Oil with or without additives is not permitted

### 2.1.8 Coolant

Coolant type and specifications are detailed into the “Rotax Operator’s Manual” and in its related documents.

### 2.1.9 Propeller

Manufacturer:	GT Tonini
Model:	GT-2/173/VRO-SRTC FW 101
Propeller type:	Wood twin blade fixed pitch
Diameter:	1730 mm (68”) (no reduction permitted)

### 2.1.10 Fuel

Two tanks:	35 liters each (9.24 gallons) / optional 45 liters (11.9 gallons)
Total fuel capacity:	70 liters (18.48 gallons) / optional 90 liters (23.8 gallons)
Usable fuel quantity:	69 liters (18.22 gallons) / optional 89 liters (23.5 gallons)

#### NOTE

During all phases of flight, both tanks normally supply engine fuel feed

#### Warning

Compensate for uneven fuel tank levels by closing the fuel valve on the tank with more fuel making sure that one fuel valve is in the on position at all times.

### 2.1.11 Approved Fuel

Min. RON 95 (AKI 91 Premium USA)
AVGAS 100LL (see Warning below)

#### Warning

Prolonged use of Aviation Fuel Avgas 100LL results in greater wear of valve seats and greater combustion deposits inside cylinders due to higher lead content. It is therefore suggested to avoid using this type of fuel unless strictly necessary.

### 2.1.12 Powerplant Instrument Markings

Powerplant instrument markings and their color code significance are shown below:

Instrument		Red line Minimum limit	Green arc Normal operating	Yellow arc Caution	Red line Maximum limit
Engine Tach	Rpm	-----	1400-5500	5500-5800	5800
Oil Temp.	°C	50	90-110	50 - 90 110-130	130°C
Cylinder heads temp.	°C	-----	50 - 135	-----	135°C
Oil pressure	Bar	0.8	2 – 5	0.8 – 2 5 – 7	7
Fuel Pressure	PSI	2.2	2.2 – 5.8		5.8

### 2.1.13 Other Instrument Markings

Instrument	Red line Minimum limit	Green arc Normal operating	Yellow arc Caution	Red line Maximum limit
Voltmeter	10 Volt	12 - 14 Volt	----	----
Suction gauge (if installed)	4.0 in. Hg	4.5 – 5.5 in. Hg	----	----

### 2.1.14 Weights

Maximum takeoff weight:	600 kg (1320 lbs)
Maximum landing weight:	600 kg (1320 lbs)
Maximum baggage weight:	20 kg (44 lbs)

### 2.1.15 Center of Gravity Limits

Forward limit	20% MAC 1,685 m (66,34")
Aft limit	33% MAC 1,867 m (73,50")
Datum	Propeller support flange w/o spacer
Bubble Level	Cabin floor

#### Warning

It is the pilot's responsibility to insure that airplane is properly loaded

### 2.1.16 Approved Maneuvers

This aircraft is intended for non-aerobatic operation only. Non-aerobatic operation includes:

- Any maneuver pertaining to “normal” flight
- Stalls (except whip stalls)
- Lazy eights
- Chandelles
- Turns in which the angle of bank is not more than 60°
- Acrobatic maneuvers are not approved
- 1 ½ turn spins for flight instruction only with trained CFI

Recommended entry speeds for each approved maneuver are as follows:

Maneuver	Speed (KIAS)	Speed (KCAS)
Lazy eight	93	88
Chandelle	93	88
Steep turn (max 60°)	93	88
Stall / Spin	Slow deceleration (1 Knots/sec)	

#### Warning

Limit load factor could be exceeded by moving the flight controls abruptly to full control deflection at a speed above  $V_A$  (93 KIAS [88 KCAS], Maneuvering Speed).

### 2.1.17 Maneuvering Load Factor Limits

Maneuvering load factors are as follows:

Flaps		
0°	+4	-2
35°	+1.9	0

### 2.1.18 Flight Crew

Minimum crew for flight is one pilot seated on the left side.

### 2.1.19 Kinds of Operations

#### 2.1.20 Day VFR

The airplane, in standard configuration, is approved only for day VFR operations under VMC:

- Altimeter
- Airspeed Indicator
- Compass
- Fuel Gauges
- Oil Pressure Indicator
- Oil Temp. Indicator
- Cylinder Head Temp. Indicator
- Tachometer

Flight into expected and/or known-icing conditions is prohibited

**2.1.21 Night**

Night flight is approved if the aircraft is equipped as per the ASTM standard F2245-06 A2 - LIGHT AIRCRAFT TO BE FLOWN AT NIGHT as well as any pertinent FAR.

**NOTE**

The FAA requires that the pilot possesses a minimum of a Private Pilot certificate and a current medical to fly at night. See the FARs for more information.

**2.1.22 IFR**

TBA

**2.1.23 Demonstrated Crosswind Safe Operations**

Demonstrated crosswind component is 15 knots.

**2.1.24 Service Ceiling**

13,110'

**2.1.25 Limitation Placards**

See Section 8

## SECTION 3

# WEIGHT & BALANCE

### 3 Introduction

This section describes the procedure for establishing the basic empty weight and moment of the aircraft. Loading procedure information is also provided.

#### 3.1 Aircraft weighing procedures

##### 3.1.1 Preparation

- Carry out weighing procedure inside closed hangar
- Remove from cabin any objects left unintentionally
- Insure Flight Manual is on board
- Align nose wheel
- Drain fuel via the specific drain valve
- Oil, hydraulic fluid and coolant to operating levels
- Move sliding seats to most forward position
- Raise flaps to fully retracted position (0°)
- Place control surfaces in neutral position
- Place scales (min. capacity 200 kg 440 pounds) under each wheel
- Level the aircraft using cabin floor as datum
- Center bubble on level by deflating nose tire
- Record weight shown on each scale
- Repeat weighing procedure three times

##### 3.1.2 Calculate empty weight Weighing

- Record weight shown on each scale
- Repeat weighing procedure three times
- Calculate empty weight

##### 3.1.3 Determination of C.G. location

- Drop a plumb bob tangent to the leading edge (in non-tapered area of one half-wing, approximately one meter from wing root) and trace reference mark on the floor.
- Repeat operation for other half-wing.
- Stretch a taught line between the two marks
- Measure the distance between the reference line and main wheel axis
- Using recorded data it is possible to determine the aircraft's C.G. location and moment (see following table)



### 3.2 Weighing report

Model Echo Super \_\_\_\_\_ S/N \_\_\_\_\_ Date \_\_\_\_\_

Datum: Propeller support flange w/o spacer. - Equipment list, date: \_\_\_\_\_

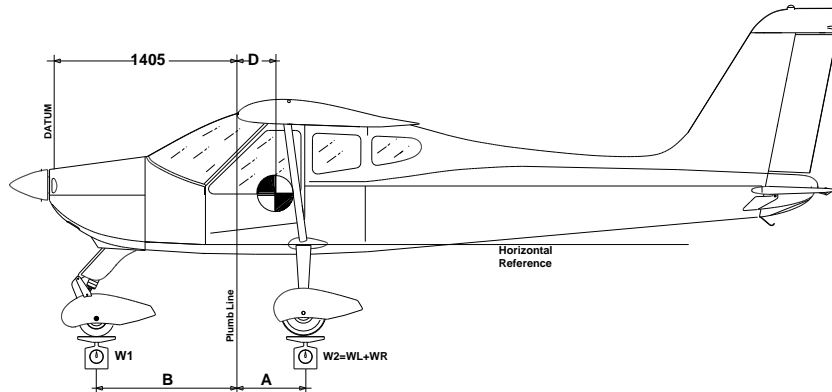

	Kg		meters
Nose wheel weight	$W_1 =$	Plumb bob distance LH wheel	$A_L =$
LH wheel weight	$W_L =$	Plumb bob distance RH wheel	$A_R =$
RH wheel weight	$W_R =$	Average distance $(A_L + A_R)/2$	$A =$
$W_2 = W_L + W_R =$		Bob distance from nose wheel	$B =$

Empty weight <sup>(1)</sup>  $W_e = W_1 + W_2 =$

$$D = \frac{W_2 \cdot A - W_1 \cdot B}{W_e} = \quad m \quad \quad D\% = \frac{D}{1.4} \cdot 100 =$$

Empty weight moment:  $M = [(D+1.405) \cdot W_e] = \quad Kg \cdot m$

Maximum takeoff weight	$W_T =$ 600 kg
Empty weight	$W_e =$
Maximum payload $W_T - W_e$	$W_u =$

Sign: \_\_\_\_\_

1 - Including unusable fuel (2.3 kg).

#### 3.2.1 Center of Gravity Limits

Forward limit	20% MAC 1,685 m (66,34")
Aft limit	33% MAC 1,867 m (73,50")
Datum	Propeller support flange w/o spacer
Bubble Level	Cabin floor

### 3.2.2 Distances from the datum

The mean distances of the occupants, baggage and fuel from the datum are:

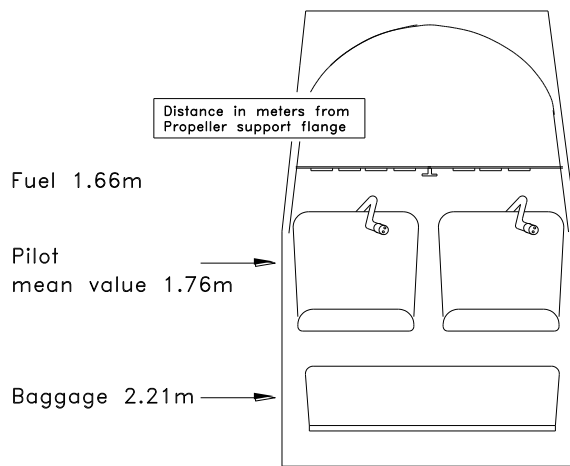

Figure 3-4

### 3.3 Weight and Balance

In order to compute the weight and balance of this aircraft, we have provided the following loading charts. This will reduce the amount of math you need. To compute weight and balance use the formula:

$$\text{Weight} * \text{Arm} = \text{Moment.}$$

Pilot/Pax				Fuel			Baggage	
Weight	Moment	Weight	Moment	Gallons	Weight	Moment	Weight	Moment
10	692.95	260	18016.63	1	6	392.15	5	435.06
20	1385.89	270	18709.57	2	12	784.29	10	870.12
30	2078.84	280	19402.52	3	18	1176.44	15	1305.18
40	2771.79	290	20095.47	4	24	1568.58	20	1740.24
50	3464.74	300	20788.42	5	30	1960.73	25	2175.30
60	4157.68	310	21481.36	6	36	2352.87	30	2610.36
70	4850.63	320	22174.31	7	42	2745.02	35	3045.42
80	5543.58	330	22867.26	8	48	3137.16	40	3480.48
90	6236.52	340	23560.20	9	54	3529.31	44	3828.53
100	6929.47	350	24253.15	10	60	3921.45		
110	7622.42	360	24946.10	11	66	4313.60		
120	8315.37	370	25639.05	12	72	4705.74		
130	9008.31	380	26331.99	13	78	5097.89		
140	9701.26	390	27024.94	14	84	5490.03		
150	10394.21	400	27717.89	15	90	5882.18		
160	11087.16	410	28410.84	16	96	6274.32		
170	11780.10	420	29103.78	17	102	6666.47		
180	12473.05	430	29796.73	18	108	7058.61		
190	13166.00	440	30489.68	19	114	7450.76		
200	13858.94	450	31182.62	20	120	7842.90		
210	14551.89	460	31875.57	21	126	8235.05		
220	15244.84	470	32568.52	22	132	8627.19		
230	15937.79	480	33261.47	23	138	9019.34		
240	16630.73	490	33954.41	24	144	9411.48		
250	17323.68	500	34647.36	25	150	9803.63		
				26	156	10195.77		

Meters	Inches	
1.66	65.36	Fuel
1.76	69.29	Pax
2.21	87.01	Baggage

To computer weight and balance:

1. Get moments from loading charts
2. Obtain the empty weight and moment from the most recent weight and balance
3. Insert the weights and the moments for fuel, occupants and baggage from the previous chart
4. Total the weight and the moment columns
5. Divide the total moment by the total weight to get the arm
6. Check that the total weight does not exceed maximum gross weight of 1320 pounds
7. Check that the arm falls within the C.G. range

<b>Computation Chart</b>			
	Weight (lbs)	Arm (inches)	Moment
Empty Weight			
Fuel		65.36	
Pilot & Passenger		69.29	
Baggage		87.01	
<b>Totals</b>			

<b>C.G. Range</b>		
Meters	1.685	1.867
Inches	66.34	73.50
<b>Max Weight</b>	<b>Pounds</b>	<b>Kilograms</b>
	1320.00	600.00

<b>Example Problem</b>			
	Weight (lbs)	Arm (inches)	Moment
Empty Weight	748.9	67.79	50767.93
Fuel	150.0	65.36	9803.63
Pilot & Passenger	300.0	69.29	20788.42
Baggage	20.0	87.01	1740.24
<b>Totals</b>	<b>1218.9</b>	<b>68.18</b>	<b>83100.22</b>

In this example, the gross weight is under the max gross weight of 1320 pounds and the Arm or C.G. is within the C.G. range listed above.

### 3.3.1 Loading

Baggage compartment is designed for a maximum load of 44 pounds. Baggage size shall prevent excessive loading of utility shelf (maximum pressure 12.5 kg/dm<sup>2</sup>). Maximum baggage size is: 80x45x32 cm . Baggage shall be secured using a tie-down net to prevent any baggage movement during maneuvers.

### 3.4 Equipment List

The following is a comprehensive list of TECNAM standard and optional supplied equipment for the P92. The list consists of the following groups:

- A. Engine and accessories
- B. Landing gear
- C. Electrical system
- D. Instruments
- E. Avionics

The following information describes each listing:

- Part-number to uniquely identify the item type
- Item description
- Serial number
- Weight in kilograms
- Distance in meters from datum

#### NOTE

Items marked with an asterisk (\*) are part of basic installation.

Equipment list		A/C s/n		Date:	
Ref.	Description & p/n	s/n	Inst	Weight kg	Datum m
<b>Engine &amp; accessories</b>					
A1	Engine Rotax 912S2 or 912ULS		*	61.0	0.32
A2	Propeller Tonini GT-2/173/VRR-SRTC FW101		*	6.0	-0.13
A3	Exhaust and manifolds - p/n 973670	--	*	4.50	0.55
A4	Heat exchanger - p/n 92-11-830	--	*	2.00	0.55
A5	Oil Reservoir (full) - p/n 956.137	--	*	4.00	0.64
A6	Oil radiator - p/n 886 025	--	*	0.40	0.07
A7	Liquid coolant radiator. - p/n 995.697	--	*	0.90	0.33
A8	Air filter K&N - p/n 33-2544	--	*	0.40	0.60
<b>Landing gear and accessories</b>					
B1	Main gear spring-leafs - p/n 92-8-300-1	--	*	5.700	1.94
B2	Main gear wheel rims. - Cleveland 40-78B	--	*	2.050	1.94
B3	Main gear tires.-Air Trac 5.00-5 AA1D4	--	*	2.580	1.94
B4	Disk brakes – Marc Ingegno	--	*	0.800	1.94
B5	Nose gear wheel rim - p/n 92-8-880-1	--	*	1.300	0.310
B6	Nose gear tire - Sava 4.00-6	--	*	1.200	0.460
B7	Nose gear fairing p/n 92-8-410-1/2	--	*	1.500	0.460
B8	Main gear fairing p/n 92-8-420-1/2	--	*	1.500	1.930
B9	Nose gear shock p/n 92-8-200-000	--	*	1.450	0.465

Equipment list		A/C S/N		Date:	
Ref.	Description & p/n	s/n	Inst	Weight kg	Datum m
	<b>Electrical system</b>				
C1	Battery FIAMM 6H4P 12V 18Ah		*	6.00	0.71
C2	Regulator, rectifier - p/n 945.345		*	0.20	0.82
C3	Battery relay - p/n 111-226-5		*	0.30	2.59
C4	Flaps actuator control - CALA33X150/c21A		*	2.20	2.30
C5	Trim actuator control MAC6A		*	0.40	5.73
C6	Overvoltage sensor OS75-14 or ZEFTRONICS V1510A		*	0.30	0.80
C7	Strobe light - AS A555A-V-14V			0.15	5.89
C8	Navigation lights - AS W1285			0.15	1.75
C9	Stall warning - AS 164R			0.10	1.36
C10	Landing light - AS GE 4509		*	0.50	1.38
	<b>Instruments</b>				
D1	Altimeter United Instruments p/n 5934PM-3 or LUN 1128.10B4 –TSO C10b		*	0.39	1.35
D2	Airspeed Ind. – UMA T6-311-161 - TSO C2b		*	0.30	1.35
D3	Compass - Airpath C2300- TSO		*	0.29	1.35
D4	Clock - Quartz Chronometer LC2 AT420100			0.15	1.35
D5	Vertical speed indicator – VSI 2FM-3		*	0.35	1.35
D6	Turn and Bank Indicator – FALCON GAUGER TC02E-3-1			0.56	1.35
D7	Attitude Indicator - GH-02V-3			1.10	1.35
D8	Directional Gyro – FALCON GAUGER DG02V-3			1.10	1.35
D9	OAT Indicator – VDO 397035001G			0.05	1.35
D10	Oil & head temp. Indicator VDO 641-011- 7047/-7048		*	0.10	1.35
D11	Oil Temp. Ind. - VDO 644-001-7030		*	0.10	1.35
D12	Trim Position Indicator -MAC S6A		*	0.05	1.35
D13	Engine RPM Ind. Aircraft Mitchell. D1- 112-5041		*	1.10	1.35
D14	Fuel Quantity Ind. Road GmbH XID4000800		*	0.56	1.35
D15	Voltmeter Ind. VDO 190-037-001G or Speed Com Instruments 0203		*	010	1.35
D16	Fuel Pressure Ind. Mitchell Aircraft Inst. 10-25-058		*	010	1.35

Equipment list		A/C s/n		Date:	
Ref.	Description & p/n	s/n	Inst	Weight kg	Datum m
	<b>Avionics</b>				
E4	GPS/NAV Receiver and R/T COM GNS 430			2.31	1.35
E5	R/T VHF COMM ICOM IC-A200			1.20	1.35
E6	ELT ACK - Model E-01			1.10	2.74
E7	Transponder-Garmin GTX320			1.00	1.35
E7	Transponder-Garmin GTX327			1.00	1.35
E8	Audio panel -Garmin GMA 340			0.50	1.35
E9	Vor/Loc Indicator-Garmin GI106A			0.64	1.35
E10	Transponder Antenna-Bendix/King KA60			0.17	1.09
E11	Transponder Antenna Garmin GTX320/327			0.17	1.09
E12	Mic - Telex TRA 100			0.17	1.90
E13	GPS Antenna Garmin GA56			0.27	1.08
E14	Comm Antenna Command Industries CI 291			0.34	3.30
E15	VOR/ILS Antenna. Command Industries CI 138C			0.26	5.80
E16	ELT Antenna Kit Model E-01			0.21	2.70
E17	Fire Extinguisher Enterprises Ltd BA51015-3			2.20	2.32
E18	First Aid Kit			0.28	2.30
E19	Altitude Encoder- Amery King Ak-30			0.25	1.00

## SECTION 4 PERFORMANCE

### 4 Introduction

This section provides all necessary data for accurate and comprehensive planning of flight activity from takeoff to landing. Data reported in graphs and/or tables were determined using:

- “Flight test data” with conditions as prescribed by ASTM and bilateral agreements
- Aircraft and engine in good condition
- Average piloting techniques

Each graph or table was determined according to ICAO Standard Atmosphere (ISA - MSL); evaluations of the impact on performance were carried out by theoretical means for:

- Airspeed
- External temperature
- Altitude
- Weight
- Type and condition of runway

#### 4.1 Use of Performance Charts

Performance data is presented in tabular or graphical form to illustrate the effect of different variables such as altitude, temperature and weight. Given information is sufficient to plan journey with required precision and safety. Additional information is provided for each table or graph.



## 4.2 Airspeed Indicator System Calibration

Graph shows calibrated airspeed  $V_{CAS}$  as a function of indicated airspeed  $V_{IAS}$

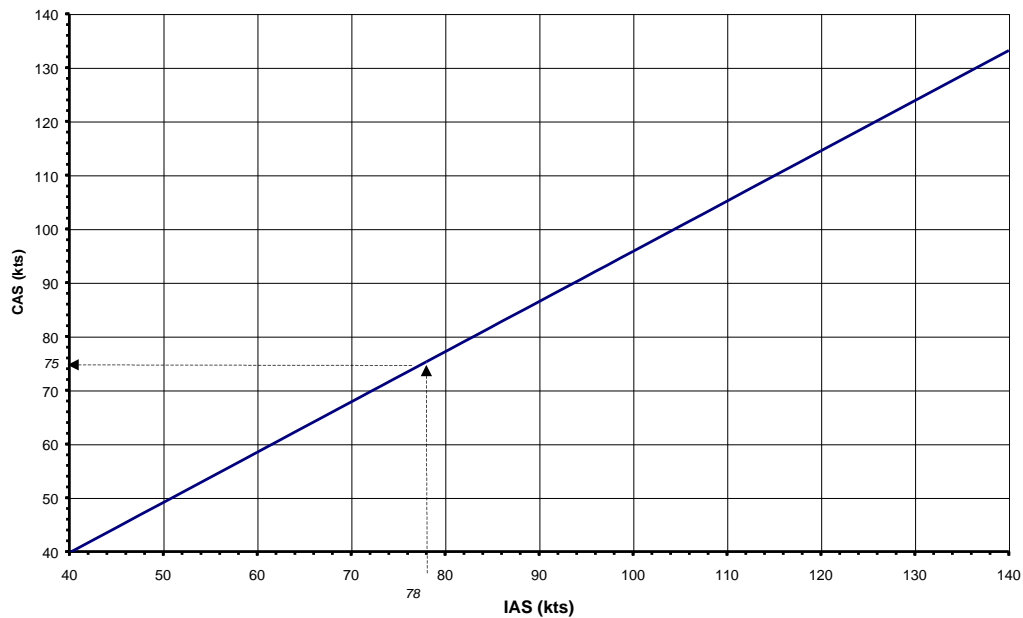

Fig. 4-1 Calibrated vs. Indicated Airspeed

### 4.3 ICAO Chart

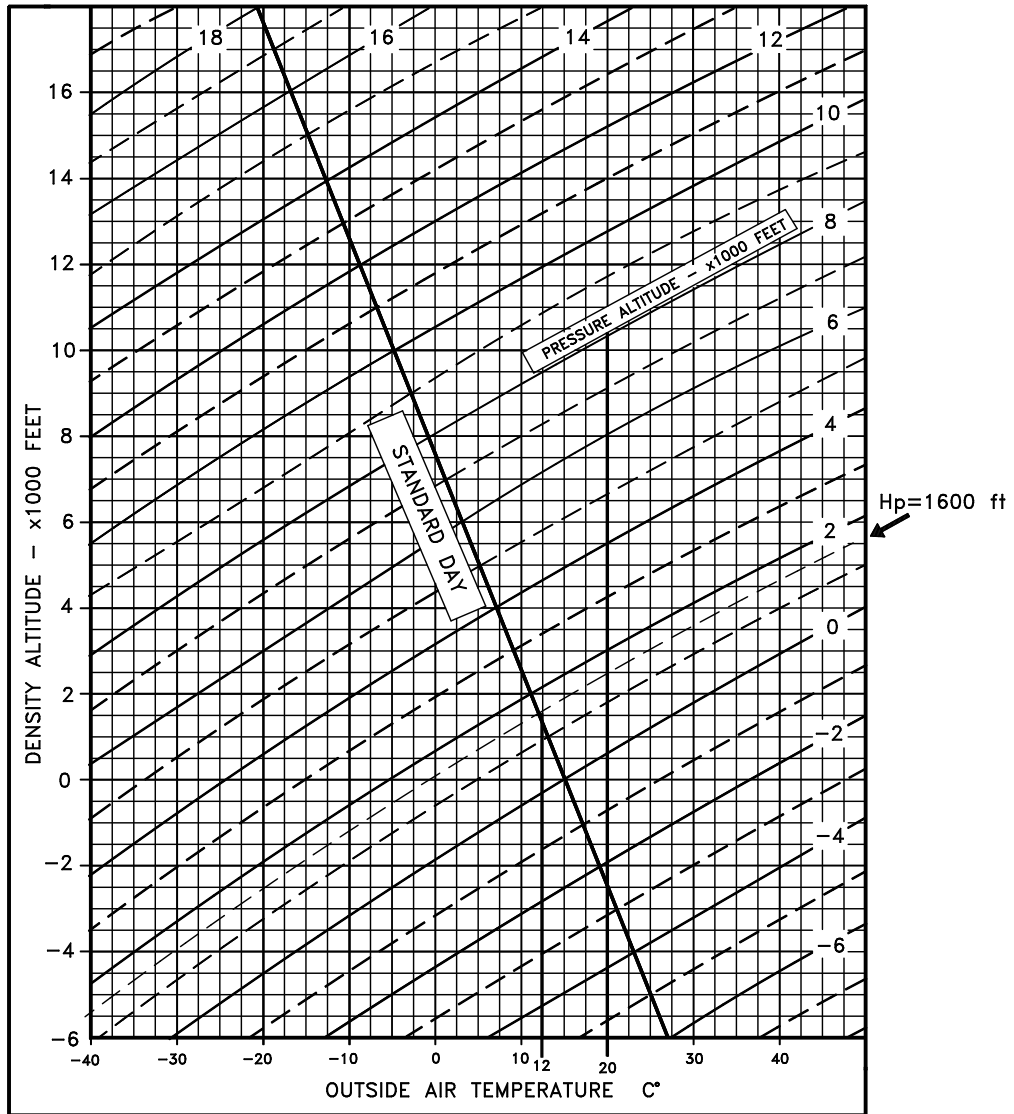

Fig. 4-2 ICAO CHART

### 4.4 Stall Speeds

Conditions:

- Weight 600 kg (1320 lbs)
- Throttle: idle
- No ground effect

**NOTE**

Altitude loss during conventional stall recovery as demonstrated during test flights is approximately 100ft with banking under 30°.

		LATERAL BANKING							
		0°		30°		45°		60°	
FLAPS		KIAS	KCAS	KIAS	KCAS	KIAS	KCAS	KIAS	KCAS
0°		<b>44</b>	43	<b>47</b>	46	<b>52</b>	51	<b>63</b>	61
15°		<b>42</b>	41	<b>45</b>	44	<b>50</b>	49	<b>60</b>	58
35°		<b>39</b>	39	<b>42</b>	41	<b>47</b>	46	<b>56</b>	55

## 4.5 Crosswind

Maximum demonstrated crosswind velocity is 15 knots

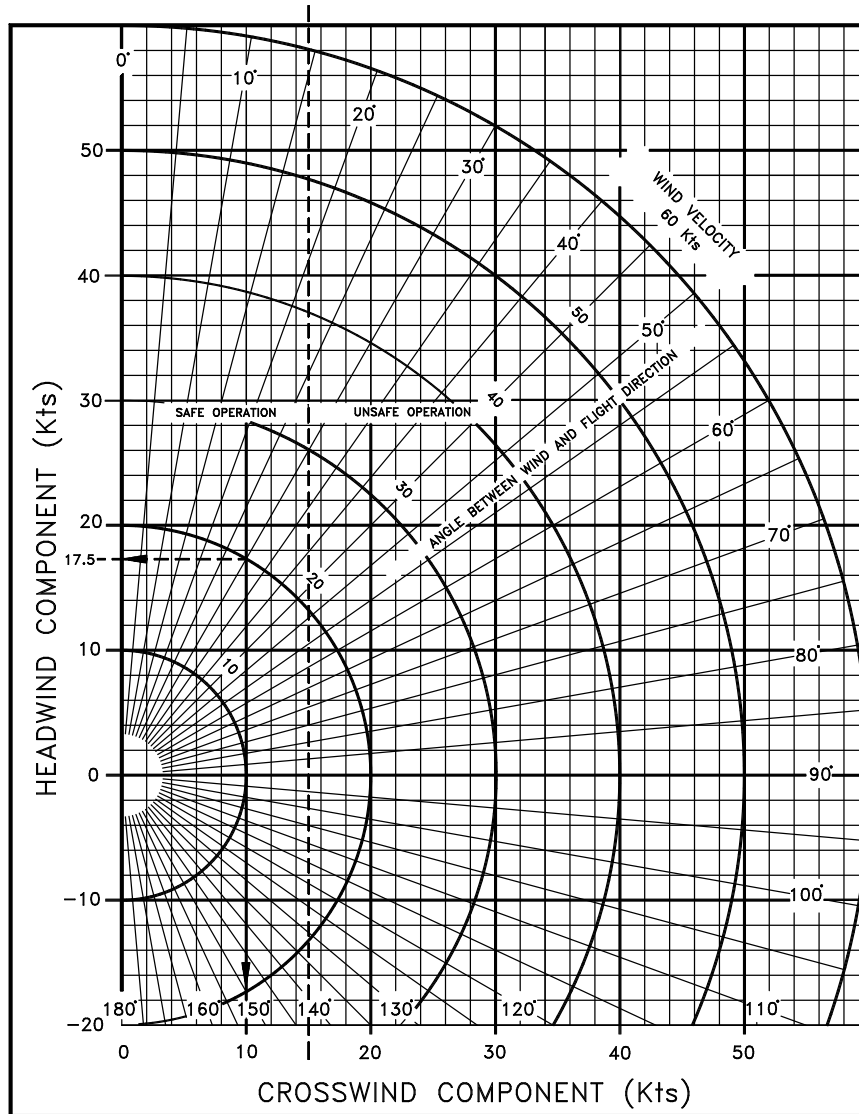

Fig. 4-3 Crosswind chart

## 4.6 Takeoff Performance

### TAKEOFF DISTANCE

Conditions:

Flaps: 15°	Runway: dry, compact, grass
Engine: full throttle	Slope: 0° Wind: zero
V <sub>r</sub> = 48 KIAS [47KCAS]	V <sub>LO</sub> = 49 KIAS [48KCAS]
V <sub>x</sub> flaps 15 = 56 KIAS [55KCAS]	R/C ≥ 200 ft/min

Decrease distances by 10% for each 10 Knots of headwind. Increase distances by 20 % for each 10 Knots of tailwind  
For dry and paved runway operation decrease ground run by 6 %.

⇒ Example:

Given	Find
O.A.T. = 15°C	TOD = 253m (830')
Pressure-altitude = 2900 ft Weight = 450 Kg (992')	TOR = 117 m (384')

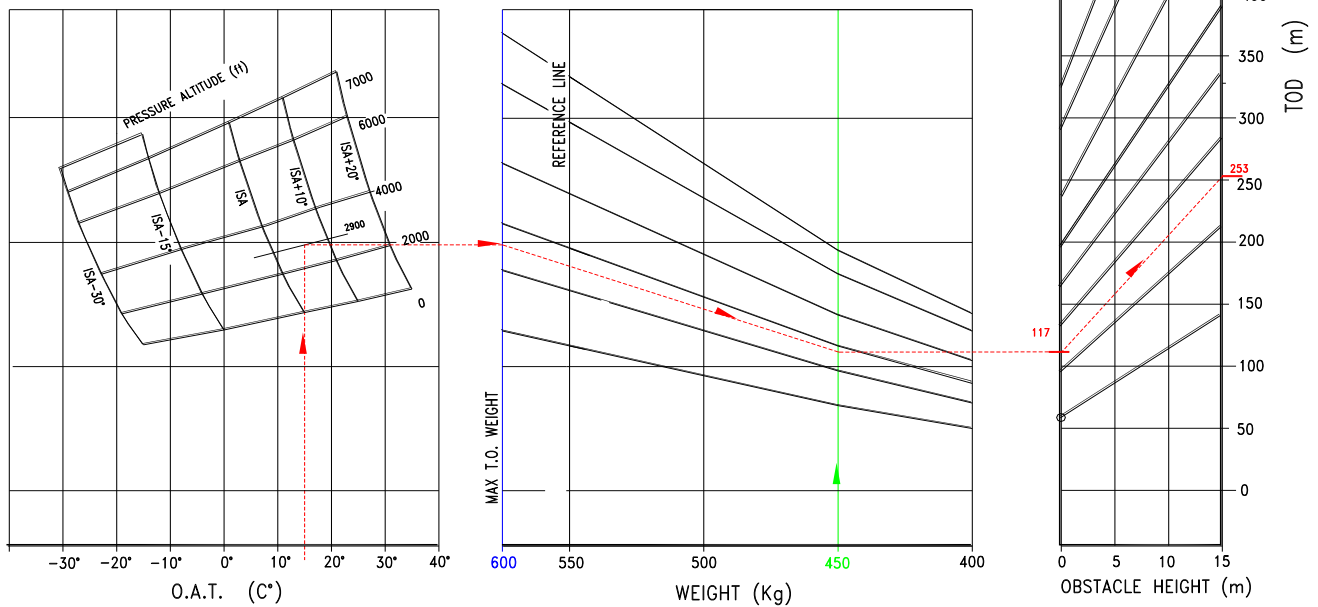

Fig. 5-4 Takeoff performance

### 4.7 Landing Distance

**CONDITIONS:**

Maximum weight = 600 kg (1320 lbs)	Engine: throttle idle
Brakes: maximum braking	Runway: dry, compact grass
Slope: 0°	Wind: zero
Conditions: ISA	Flaps: 35°

**NOTE**

*Decrease distances by 10% for each 10 Knots of headwind. Increase distances by 20 % for each 10 Knots of tailwind;*

*For dry and paved runway operation increase ground run by 10%*

*If it becomes necessary to land without flap extension (flap malfunction), increase approach speed by 10 Knots, increase by landing distance by 40% distance pertaining to flap setting at 35° and increase  $V_x$  to 58 KIAS [57KCAS]*

*$V_x$  15 flaps (speed over obstacle) is 48 KIAS [47KCAS]*

<b>Hp (ft)</b>	0	1000	2000	3000	4000	5000	6000	7000
<b>GR (m)</b>	100	103	106	109	112	116	119	123
<b>GR (ft)</b>	328	337	348	356	367	388	390	403
<b>LD (m)</b>	252	256	260	264	268	273	279	282
<b>LD (ft)</b>	827	840	853	866	879	895	915	925

HP = pressure altitude

GR = ground run

LD = 50' obstacle

## 4.8 Climb Performance

### CLIMB RATE IN CLEAN CONFIGURATION

Conditions:

- Flap: 0°
- Engine: Full throttle
- $V_Y = 68$  KIAS [66KCAS]

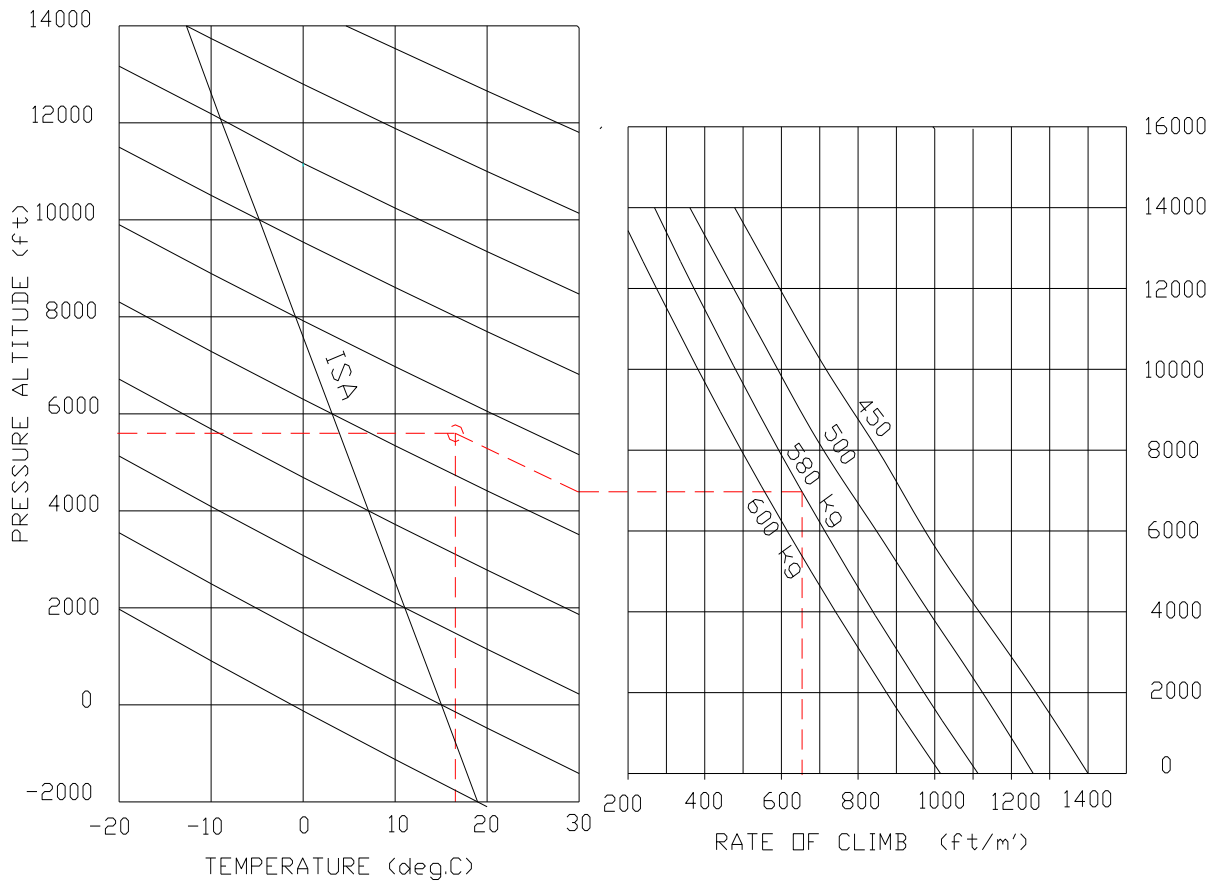

Fig. 5-5 CLIMB

⇒ Example:

**Given**

O.A.T. = 17°C

Pressure altitude = 5600 ft

Weight = 580 Kg

**Find**

Rate of climb = 654 ft/min

## 4.9 Cruise

Maximum takeoff weight = 600 kg (1320 lbs)

(1) Fuel tanks 2x35 liters (9.2 gal) (less the unusable fuel)

(2) Fuel tanks 2x45 liters (11.9 gal) (less the unusable fuel)

*Pressure altitude H<sub>p</sub>: 0 ft OAT: +15°C*

Engine RPM	Speed KTAS	Consumption (gal/h)	1 Endurance (hrs)		1 Range (N.m.)		
			(1)	(2)	(1)	(2)	
55%	4600	96	4	4.5	5.8	431	599
65%	5000	102	4.8	3.7	4.9	382	495
75%	5200	108	5.3	3.4	4.4	364	472

*Pressure altitude H<sub>p</sub>: 2000 ft OAT: +11°C*

Engine RPM	Speed KTAS	Consumption (gal/h)	1 Endurance (hrs)		1 Range (N.m.)		
			(1)	(2)	(1)	(2)	
55%	4600	98	4	4.5	5.8	440	571
65%	5000	106	4.8	3.7	4.9	397	515
73%	5200	109	5.2	3.5	4.6	387	501

*Pressure altitude H<sub>p</sub>: 4000 ft OAT: +7°C*

Engine RPM	Speed KTAS	Consumption (gal/h)	1 Endurance (hrs)		1 Range (N.m.)		
			(1)	(2)	(1)	(2)	
55%	4600	101	4	4.5	5.8	454	588
60%	5000	105	4.5	4.0	5.1	416	540
70%	5200	110	4.9	3.6	4.7	401	520

*Pressure altitude H<sub>p</sub>: 6000 ft OAT: +3°C*

Propeller RPM	Speed KTAS	Consumption (gal/h)	1 Endurance (hrs)		1 Range (N.m.)		
			(1)	(2)	(1)	(2)	
55%	5000	104	4	4.5	5.8	467	606
60%	5200	108	4.5	4.0	5.1	429	556

<sup>1</sup> Range and endurance are intended approximate and referred to a “zero” wind condition.

*Pressure altitude H<sub>p</sub>: 8000 ft OAT: -0.8°C*

Propeller RPM	Speed KTAS	Consumption (gal/h)	1 Endurance (hrs)		1 Range (N.m.)		
			(1)	(2)	(1)	(2)	
55%	5150	99	4	4.5	5.8	445	578
58%	5200	102	4.3	4.2	5.4	428	556

*Pressure altitude H<sub>p</sub>: 10000 ft OAT: -5°C*

Propeller RPM	Speed KTAS	Consumption (gal/h)	1 Endurance (hrs)		1 Range (N.m.)		
			(1)	(2)	(1)	(2)	
55%	5200	100	4	4.5	5.8	450	585

*Pressure altitude H<sub>p</sub>: 12000 ft OAT: -9°C*

Propeller RPM	Speed KTAS	Consumption (gal/h)	1 Endurance (hrs)		1 Range (N.m.)		
			(1)	(2)	(1)	(2)	
50%	5200	98	3.7	4.8	6.2	475	617



## 4.10 Balked Landing

### RATE OF CLIMB: BALKED LANDING

#### CONDITIONS:

Maximum weight = 600 kg (1320 lb)

Engine: full throttle

Flaps: 35°

$V_x$  15 flaps = 48 KIAS [47 KCAS]

#### NOTE

During balked landing maneuver, flaps should be retracted immediately after applying full power.

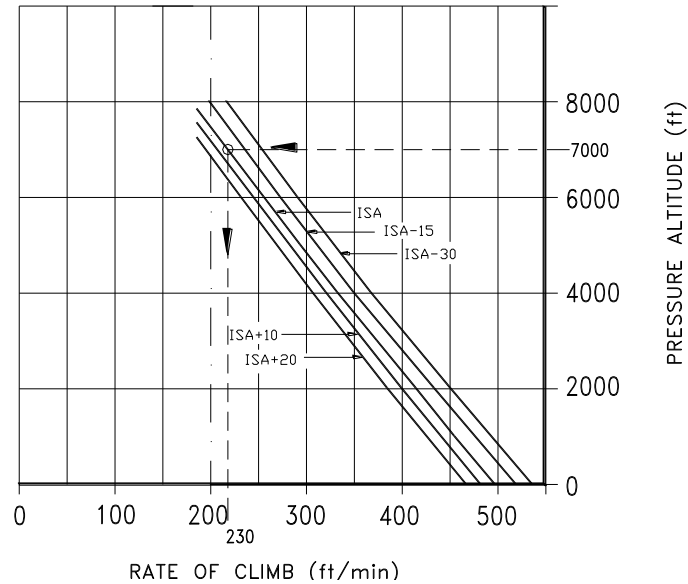

Fig.5-6. BALKED LANDING

## 4.11 Effects of Rain and Insects

Flight tests have demonstrated that neither rain nor insect impact build-up on leading edge has caused substantial variations on aircraft's flight qualities.

## 4.12 Noise Data

Noise level was determined according to JAR-36 Sub. C Ed.23 May 1997 ICAO/Annex 16 Chap.10 Issue 1993, and resulted equal to 63.6 dB.

## SECTION 5

# EMERGENCY PROCEDURES

### 5 Introduction

Section 6 includes checklists and detailed procedures to be used in the event of emergencies. Emergencies caused by a malfunction of the aircraft or engine is extremely rare if appropriate maintenance and pre-flight inspections are carried out. In case of emergency, suggestions of the present section should be considered and applied as necessary to correct the problem.

Before operating the aircraft, the pilot should become thoroughly familiar with the present manual and, in particular, with the present section. Further, a continued and appropriate training program should be provided.

In case of emergency the pilot should act as follows:

- Keep control of the airplane
- Analyze the situation
- Apply the pertinent procedure
- Inform the Air Traffic Control if time and conditions allow

<b>AIRSPEEDS FOR SAFE OPERATION IN EMERGENCY SITUATIONS - KIAS</b>		<b>KCAS</b>
Engine failure after takeoff (15 degrees of flaps)	<b>60</b> Knots	<b>58</b> Knots
Engine failure during flight	<b>68</b> Knots	<b>66</b> Knots
Maneuvering speed	<b>93</b> Knots	<b>88</b> Knots
Maximum glide	<b>68</b> Knots	<b>66</b> Knots

## 5.1 Engine Failures

If an emergency arises, the basic guidelines described in this section should be considered and applied as necessary to correct the problem.

### 5.1.1 Engine Failures on Ground

#### 5.1.1.1 ENGINE FAILURE DURING TAKEOFF RUN

Throttle:..... IDLE  
Brakes:..... APPLY AS NEEDED  
Ignition Switches:..... OFF  
Master switch: ..... OFF  
*When the airplane is under control*  
Fuel selector valves: ..... OFF

### 5.1.2 Engine Failure during Flight

#### 5.1.2.1 ENGINE FAILURE IMMEDIATELY AFTER TAKEOFF

Airspeed: ..... 60 knots  
Find a suitable place on the ground to land safely. The landing should be planned straight ahead with only small changes in directions not exceeding 45° to the left or 45° to the right  
Flaps: ..... AS REQUIRED  
Throttle:..... AS REQUIRED  
*At touch down*  
Ignition Switches:..... OFF  
Master switch: ..... OFF  
Fuel selector valves: ..... OFF

#### 5.1.2.2 IRREGULAR ENGINE RPM

Throttle:..... CHECK  
Engine gauges: ..... CHECK  
Fuel quantity indicators: ..... CHECK  
Carburetor heat (optional): ..... ON  
*If the engine continues to run irregularly:*  
Fuel selector valve:..... BOTH ON  
*If the engine continues to run irregularly:*  
Land as soon as possible

#### 5.1.2.3 LOW FUEL PRESSURE

If the fuel pressure indicator falls below the (0.15 bar) limit:  
Fuel quantity indicators: ..... CHECK  
If the engine continues to run irregularly:  
Fuel selector valves: ..... BOTH ON  
*If the fuel pressure continues to be low:*  
Land as soon as possible

### 5.1.2.4 LOW OIL PRESSURE

- Oil temperature:..... CHECK  
*If the temperature tends to increase:*  
 If stable within the green arc: ..... LAND as soon as possible  
 If increasing:..... LAND as soon as possible and be alert for impending engine failure

### 5.1.2.5 IN-FLIGHT ENGINE RESTART

- Altitude:..... Preferably below 4000 ft  
 Carburetor heat (if installed): ..... ON  
 Fuel selector valves: ..... BOTH ON  
 Throttle:..... MIDDLE POSITION  
 Ignition switches: ..... ON  
 Master Switch:..... START  
*If the restart attempt fails:*  
 Procedure for a forced landing: ..... APPLY  
*In case of an engine restart:*  
 Land as soon as possible

### 5.1.2.6 ENGINE OUT GLIDE

- Flaps:..... RETRACT  
 Speed:..... 68 KIAS [66KCAS]  
 Electric equipments: ..... OFF  
 In-flight engine restart:..... If conditions permit, try to restart several times

#### NOTE

Glide ratio is 12.8 therefore with 1000 ft of altitude; it is possible to cover ~2 nautical miles in zero wind conditions.

## 5.2 Smoke and Fire

### 5.2.1 Engine Fire while parked

- Fuel selector valves: ..... OFF  
 Ignition Switches:..... OFF  
 Master switch: ..... OFF  
 Parking brake: ..... SET  
 Escape rapidly from the aircraft

### 5.2.2 Engine Fire during Takeoff

- Throttle:..... IDLE  
 Brakes:..... AS NEEDED  
*With the airplane is under control:*  
 Fuel selector valves: ..... OFF  
 Cabin heating: ..... OFF  
 Ignition Switches:..... OFF  
 Master switch: ..... OFF  
 Parking brake: ..... SET  
 Escape rapidly from the aircraft

### 5.2.3 Engine Fire in-flight

- Cabin heat: ..... OFF  
 Fuel selector valves: ..... OFF  
 Throttle:..... FULL IN until the engine stops running

Cabin vents:..... OPEN  
 Ignition Switches:..... OFF  
*Do not attempt an in-flight restart*  
 Procedure for a forced landing: ..... APPLY

### 5.2.4 Cabin Fire during Flight

Cabin heat: ..... OFF  
 Cabin vents:..... OPEN  
 Doors:..... OPEN, if necessary  
 Master switch: ..... OFF  
 Try to choke the fire. Direct the fire extinguisher towards flame base  
 Procedure for a forced landing: ..... APPLY

## 5.3 Landing Emergency

### FORCED LANDING WITHOUT ENGINE POWER

Establish: ..... 68 KIAS [66KCAS]  
 Locate most suitable terrain for emergency landing, upwind if possible  
 Fuel selector valves: ..... OFF  
 Ignition Switches:..... OFF  
 Safety belts: ..... TIGHTEN  
 Doors:..... UNLATCHED  
*Landing assured:*  
 Flaps: ..... AS NECESSARY  
 Master switch: ..... OFF  
 Touchdown Speed: ..... 42 KIAS [41KCAS]

### POWER-ON FORCED LANDING

Descent: ..... ESTABLISH  
 Establish: ..... 68 KIAS  
 Flaps: ..... AS NECESSARY  
 Select terrain area most suitable for emergency landing and flyby checking for obstacles and wind direction  
 Safety belts: ..... TIGHTEN  
 Doors:..... UNLOCK  
*Landing assured:*  
 Flaps: ..... AS NECESSARY  
 Fuel selector valves: ..... OFF  
 Ignition Switches:..... OFF  
 Master switch: ..... OFF

### LANDING WITH A FLAT NOSE TIRE

Pre-landing checklist: ..... COMPLETE  
 Flaps: ..... FULL  
 Land and maintain aircraft NOSE HIGH attitude as long as possible

### LANDING WITH A FLAT MAIN TIRE

Pre-landing checklist: ..... COMPLETE  
 Flaps: ..... FULL

#### NOTE

Align the airplane on the opposite side of runway to the side with the defective tire to compensate for change in direction, which is to be expected during final rolling.

Touchdown with the GOOD TIRE FIRST and hold aircraft with the flat tire off the ground as long as possible.

## 5.4 Recovery from Unintentional Spin

Power: ..... IDLE  
Ailerons: ..... NEUTRAL (and Flaps Up)  
Rudder: ..... FULL OPPOSITE  
Elevator: ..... THROUGH NEUTRAL

### **HOLD THESE INPUTS UNTIL ROTATION STOPS, THEN:**

Rudder: ..... NEUTRAL  
Elevator: ..... RECOVER

#### **NOTE**

Use elevator control to recover to straight and level or a climbing attitude

#### **NOTE**

The first letter in each of the four primary recovery inputs spells out the acronym, PARE (pronounced “pair”). PARE is a convenient memory aid that points the way to spin recovery. The PARE format mimics the most docile spin configuration possible, affording the greatest response to recovery inputs. Errant control inputs that may aggravate the spin are avoided in the process. As a mental checklist, it forces you to focus on the appropriate recovery actions. Calling each item out loud also tends to reinforce the physical inputs.

## 5.5 Other Emergencies

### 5.5.1 UNINTENTIONAL FLIGHT INTO ICING CONDITIONS

Get away from icing conditions by changing altitude or direction of flight in order to reach an area with warmer external temperature.

Carburetor heat (optional): ..... ON

Increase rpm to avoid ice formation on propeller blades.

Cabin heat: ..... ON

#### **WARNING**

In case of ice formation on wing leading edge, stall speed may increase.

### 5.5.2 Carburetor Ice

#### 5.5.2.1 AT TAKEOFF

At takeoff, carburetor heat (optional) is normally OFF given the unlikely possibility of ice formation at full throttle

#### 5.5.2.2 IN FLIGHT

With external temperatures below 15° C, or on rainy days or with humid, cloudy, hazy or foggy conditions or whenever a power loss is detected, turn carburetor heat (optional) to ON until engine power is back to normal.

## 5.6 Electric Power System Malfunction

Electric power supply system malfunctions may be avoided by carrying out inspections as scheduled and prescribed in the Service Manual. Causes for malfunctions are hard to establish but, in any case, problems of this nature must be dealt with immediately. The following may occur:

### 5.6.1 GENERATOR LIGHT ILLUMINATES

Generator light may illuminate for a faulty alternator. If the generator light illuminates proceed as follows:

- LAND as soon as possible
- Continue flight on battery power alone; the battery is capable of supplying the electrical system for about 20 minutes with normal flight electric loads including operation of flap and trim.

## 5.7 Trim System Failure

### 5.7.1 LOCKED CONTROL

In case the trim control should not respond, act as follows:

Fuses / breakers ..... CHECK

LH/RH switch ..... CHECK for correct position

Airspeed ..... Adjust speed to control aircraft without excessive stick force

Land aircraft as soon as possible

## SECTION 6

# NORMAL PROCEDURES

## 6 Introduction

Section 6 contains checklists and the procedures for normal operation.

### 6.1 Removing and Reinstalling the Engine Cowling

#### 6.1.1 Upper Cowling

Parking brake: .....ON or chocks installed

Fuel selector valves: .....OFF

Ignition Switches: .....OFF

Master switch: .....OFF

- Unlatch all four butterfly Cam-locks mounted on the top cowling by rotating them 90° counter clockwise while slightly pushing inwards.
- Remove the four screws holding the top canopy to the bottom.
- Remove top engine cowling paying attention to propeller shaft passing through nose.

*To reinstall:*

- Rest cowling horizontal insuring proper fitting of nose base reference pins.
- Reinstall the four screws.
- Secure latches by applying light pressure, check for proper assembly and fasten Cam-locks.

#### **WARNING**

Butterfly Cam-locks are locked when tabs are horizontal and open when tabs are vertical. Verify tab is below latch upon closing.

#### 6.1.2 Lower Cowling

*After disassembling upper cowling*

- Move the propeller to a horizontal position
- Using a standard screwdriver, press and rotate 90° the two Cam-locks positioned on lower cowling by the firewall.
- Disconnect the ram-air duct from the NACA intake. Pull out the first hinge pin positioned on the side of the firewall, then, while holding cowling, pull out second hinge pin; remove cowling with downward motion.

*For installation follow reverse procedure*



## 6.2 Checklist Procedures

### 6.2.1 Pre-Flight Inspection

Before each flight, it is necessary to carry out a complete inspection of the aircraft starting with an external inspection followed by an internal inspection.

#### 6.2.1.1 Cabin Inspection

All required paperwork: ..... ONBOARD  
Weight and balance: ..... CHECK  
Safety belts used to lock controls: ..... RELEASE  
Flight controls: ..... CHECK  
*Check for freedom of movement and proper direction*  
Parking brake: ..... SET  
Friction lock: ..... CHECK  
Throttle: ..... IDLE  
Ignition Switches: ..... OFF  
Master switch: ..... ON  
Generator light: ..... ON  
Aux. Alternator switch (if installed): ..... ON  
Alternator light: ..... ON  
Flaps: ..... EXTEND  
*Visually check that flaps are fully extended and instrument indication is correct*  
Trim: ..... CHECK  
*Activate control in both directions checking for travel limits and instrument indication*  
Stall warning (optional): ..... CHECK  
Navigation lights and strobe light (optional): ..... CHECK

#### NOTE

Strobe lights won't work without the engine running

Landing light: ..... CHECK  
Fuel Tank levels: ..... CHECK  
Master switch: ..... OFF

#### WARNING

Fuel level indicated by the fuel quantity indicators (on the instrument panel) is only indicative. For flight safety, pilot should verify actual fuel quantity visually in tanks before takeoff.

### 6.2.1.2 External Inspection

It is best to follow the external inspection in the station order outlined in fig. 6-1 so nothing is missed. Visual inspection is defined as follows: check for defects, cracks, detachments, excessive play, and unsafe or improper installation as well as for general condition. For control surfaces, visual inspection also involves additional checks for freedom of movement and security.

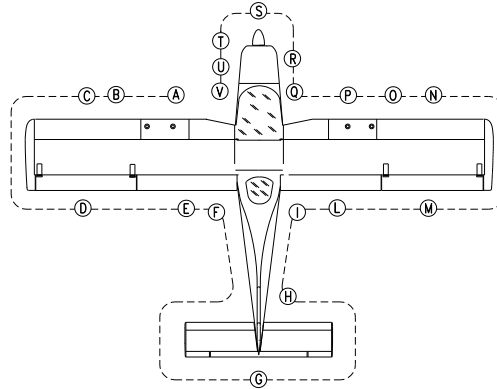

FIG. 6-1

- A. Left fuel filler cap: CHECK visually for desired fuel level and secure
- B. Pitot tube: Remove pitot tube cover and check that the pitot tube mounted on the left wing is unobstructed. Do not blow inside pitot tube.
- C. Left side leading edge and wing skin: CHECK for damage
- D. Left aileron: CHECK for damage, freedom of movement: Left tank vent: CHECK for obstructions
- E. Left flap and hinges: CHECK security
- F. Left main landing gear: CHECK inflation 23 PSI (1.6 bar), tire condition, alignment, fuselage skin condition
- G. Horizontal tail and tab: CHECK for damage, freedom of movement
- H. Vertical tail and rudder: CHECK for damage, freedom of movement (**NOTE:** do not move rudder unless nosewheel is lifted off the ground)
- I. Right side main landing gear: CHECK inflation 23 PSI (1.6 bar), tire condition, alignment, fuselage skin condition
- J. Right flap and hinges: CHECK security
- K. Right aileron: CHECK for damage, freedom of movement; Right side tank vent: check for obstructions
- L. Right leading edge and wing skin: CHECK for damage
- M. Stall indicator micro switch (optional): Check freedom of movement, turn on Master switch and check cabin acoustic warning signal is operative, turn off Master switch
- N. Right side fuel filler cap: CHECK visually for desired fuel level and secure
- O. Nose wheel strut and tire: CHECK inflation 15 PSI (1.0 bar); tire condition and condition of rubber shock absorber discs. Check the right static port for obstructions.
- P. Propeller and spinner condition: CHECK for nicks and security
- Q. Open both engine cowlings and perform the following checklist:
  - Check no foreign objects are present
  - Check the cooling system for losses, check coolant reservoir level, and insure radiator honeycomb is unobstructed
  - Check oil system for losses, check oil reservoir level, and insure radiator honeycomb is unobstructed
  - Check fuel system. Open both fuel shutoff valves and inspect fuel lines for leaks. Drain Gascolator using a cup to collect fuel. Make sure that valve is closed and not leaking. Check for water or other contaminants.
  - Engine mounts: CHECK integrity
  - Intake system: Check connection and integrity of air intake system, visually inspect that ram air intake is unobstructed
  - All parts: Check they are secure or safety wired

**WARNING**

Drain fuel with aircraft parked on level surface

- R. Engine cowlings:..... CLOSE
- S. Landing Light: ..... CHECK
- T. Tow bar and chocks: ..... REMOVE

**6.2.1.3 BEFORE START**

- Parking brake: ..... SET
- Flight controls: ..... CHECK
- Throttle:..... IDLE
- Friction lock: ..... ADJUST
- Master switch: ..... ON
- Generator light: ..... ON
- Aux. Alternator switch (if installed):..... ON
- Aux. Alternator light (if installed):..... ON
- Trim control: ..... CENTERED
- Trim switch: ..... LEFT
- Landing light: ..... CHECK
- Fuel quantity:..... CHECK

**NOTE**

Compare the fuel levels read by the fuel quantity indicators with the quantity present in the tanks

- Master switch: ..... OFF
- Seat position and safety belts: ..... ADJUST
- If flying solo:*
- Passenger belts: ..... SECURED / CLEAR OF CONTROLS
- Doors: ..... CLOSED AND LOCKED

**6.2.1.4 STARTING ENGINE**

- Brakes:..... SET
- Fuel selector valves: ..... BOTH ON
- Master switch: ..... ON
- Throttle:..... IDLE
- Choke: ..... AS NEEDED
- Propeller area: ..... CLEAR

**WARNING**

Check to insure no person or object is present in the area close to propeller

- Strobe light: ..... ON
- Ignition Switches:..... ON
- Master Switch:..... START

**NOTE**

Starter duty cycle: max of 10 seconds on followed by a cooling period of 2 minutes off

Oil pressure: ..... CHECK

**WARNING**

If oil pressure doesn't rise within 10 seconds, shut down engine.  
The maximum oil pressure for cold conditions is 7 bar.

Engine instruments: ..... CHECK  
Choke: ..... OFF  
Engine rpm: ..... 2000-2500 rpm  
Fuel pressure: ..... CHECK

**6.2.1.5 BEFORE TAXI**

Radio and Avionics (if installed): ..... ON  
Altimeter: ..... SET  
Flight Instruments: ..... SET, CHECK  
Parking brake: ..... OFF

**6.2.1.6 TAXI**

Brakes: ..... CHECK  
Flight instruments: ..... CHECK

**6.2.1.7 BEFORE TAKE-OFF**

Parking brake: ..... ON  
Engine instruments: ..... CHECK

- Oil temperature: ..... 90°-110 ° C
- Cylinder head temperature: ..... 90° - 135 ° C
- Oil pressure: ..... 2 - 5 bar
- Fuel pressure: ..... 0.15 – 0.40 bar

Generator light: ..... OFF  
External Alternator light (if installed): ..... OFF  
Throttle: ..... 4000 RPM

*To test ignition systems:*

- Maximum RPM drop with only one ignition ..... 300 rpm
- Maximum differential between LEFT or RIGHT ..... 120 rpm

Carburetor Heat (optional): ..... CHECK  
Throttle: ..... IDLE  
Fuel quantity indicators: ..... CHECK  
Fuel selector valves: ..... BOTH ON  
Flaps: ..... T/O (15°)  
Flight controls: ..... CHECK  
Trim: ..... CENTER  
Seat belts: ..... FASTENED  
Doors: ..... CLOSED AND LOCKED  
Transponder (if installed): ..... ALT

**6.2.1.8 TAKEOFF AND CLIMB**

Parking brake: ..... OFF  
Carburetor heat (optional): ..... OFF

*Taxi to line-up:*

Magnetic compass and DG (optional):..... CHECK, SET  
 Throttle:..... FULL

**NOTE**

Static RPM is approximately 5100 ± 250 rpm

Engine instruments:..... CHECK  
 Vr (Rotation speed): ..... ~ 48 KIAS [47 KCAS]

**NOTE**

Rotate to takeoff attitude and accelerate to a climb speed of 60 knots with 15° Flaps

*Above 300' AGL:*

Flaps: ..... RETRACT  
 Establish Vy clean: ..... 68 KIAS [66 KCAS]  
 Trim: ..... ADJUST  
 Cruise climb: ..... 75 – 80 KNOTS

**6.2.1.9 CRUISE**

*Reaching cruise altitude:*

Throttle:..... SET (5500 RPM Max)  
 Engine instruments:..... CHECK

- Oil temperature: ..... 90°-110 ° C
- Cylinder head temperature: ..... 90° - 135 ° C
- Oil pressure: ..... 2 - 5 bar
- Fuel pressure: ..... 0.15 – 0.40 bar

**CAUTION**

Normal position of the fuel selectors is both on. Check fuel balance and fuel pressure. If necessary, shut off the higher reading tank using the appropriate fuel shutoff valve. Check fuel pressure again. **BE SURE THAT ONE TANK IS FEEDING THE ENGINE AT ALL TIMES!**

**NOTE**

Check fuel gauges frequently with one tank shut off to prevent fuel starvation.

**6.2.1.10 BEFORE LANDING**

Landing light (if installed):..... ON  
*On downwind leg: Speed and flaps at your discretion based on traffic, etc.*  
 Traffic:..... CHECK  
 Flaps: ..... AS DESIRED  
 Optimal touchdown speed (full flaps): ..... 40 KNOTS

**6.2.1.11 BALKED LANDING**

Throttle:..... FULL  
 Airspeed: ..... 60 KIAS [58 KCAS]  
 Flaps position: ..... TO / 15 degrees  
 Airspeed: ..... 65 KIAS [63 KCAS]  
 Trim:..... ADJUST  
*Above 300' AGL:*  
 Flaps: ..... RETRACT  
 Establish Vy clean: ..... 68 KIAS [66 KCAS]  
 Trim: ..... ADJUST  
 After takeoff checklist: ..... COMPLETE

**6.2.1.12 AFTER LANDING***Taxi at an appropriate speed for conditions*Flaps: ..... UP  
Transponder: ..... STANDBY**6.2.1.13 ENGINE SHUT DOWN**

Keep engine running at 2500 rpm for about one minute in order to reduce latent heat. This can be accomplished during taxi.

**NOTE**

Do not ride the brakes to facilitate cool down. If necessary, stop for one minute with parking brake on to cool the engine.

Electrical equipment (except the Strobe Light): ..... OFF  
Ignition switches: ..... OFF  
Strobe light: ..... OFF  
Master switch: ..... OFF  
One or both fuel valves: ..... OFF  
Parking brake: ..... ON  
Chocks: ..... INSTALL  
Parking brake: ..... OFF**6.2.1.14 POSTFLIGHT CHECK**Pitot tube cover: ..... INSTALL  
Aircraft: ..... TIED DOWN  
Control locks (if available): ..... INSTALL  
Chocks: ..... INSTALL  
Parking brake: ..... OFF  
Doors: ..... CLOSED AND LOCKED

## SECTION 7

# GROUND HANDLING & SERVICE

## 7 Introduction

This section contains factory-recommended procedures for proper ground handling and routine care and servicing. It also identifies certain inspection and maintenance requirements, which must be followed if the aircraft is to retain its new-plane performance and dependability. It is recommended to follow a planned schedule of lubrication and preventive maintenance based on climatic and flying conditions encountered locally.

### 7.1 Aircraft Inspection Periods

Inspection intervals occur at 100 hours and in accordance with special inspection schedules, which are added to regularly, scheduled inspections. Correct maintenance procedures are described in the aircraft's Service Manual or in the engine's Maintenance Manual.

### 7.2 Aircraft Alterations or Repairs

For repairs, refer to aircraft's Maintenance Manual.

### 7.3 Ground Handling

#### 7.3.1 Towing

The use of a towbar is recommended. But, pulling on the propeller near the axle you can safely maneuver the aircraft. Aircraft may be steered by turning rudder or, for steep turns, by pushing lightly on tailcone to lift nose wheel.

#### 7.3.2 Parking and Tiedown

When parking airplane outdoors, head it into the wind and set the parking brake. It is preferable to use chocks if available. Tie the airplane down in severe weather and high wind conditions. Tie-down ropes shall be fastened to the wing attachments and anchoring shall be provided by ramp tie-downs. Nose gear fork can be used for front tie-down location or the tail can be tied down with the optional Tiedown point. Secure the flight controls to avoid possible weathervane damage to moving surfaces. Seatbelts may be used to latch control stick to prevent its movement.

#### 7.3.3 Jacking

Given the light empty weight of the aircraft, lifting one of the main wheels can easily be accomplished even without the use of hydraulic jacks. For an acceptable procedure please refer to the Maintenance Manual.

#### 7.3.4 Leveling

Aircraft leveling may become necessary to check wing incidence, dihedral or the exact location of CG. Longitudinal leveling verification is obtained by placing a level longitudinally, over the aft part of the cabin floor (just in front of the seat). See maintenance manual for instructions.

#### 7.3.5 Road Transport

It is recommended to secure tightly all aircraft components onto the cart to avoid damage during transport. Minimum cart size is 7x2.5 meters. It is suggested to place wings under the aircraft's bottom, secured by specific clamps. Secondary

components such as stabilator and struts shall be protected from accidental hits using plastic or other material. For correct rigging and de-rigging procedure, refer to the Maintenance Manual.

### **7.3.6 Cleaning and Care**

To clean painted surfaces, use a mild detergent such as shampoo normally used for car finish; use a soft cloth for drying. The plastic windshield and windows should never be dusted when dry; use lukewarm soapy water and dry using chamois only. It is possible to use special glass detergents but, in any case, never use products such as gasoline, alcohol, acetone or other solvents.

To clean cabin interior, seats, upholstery and carpet, it is generally recommended to use foam-type detergents.



## Section 8

# REQUIRED PLACARDS & MARKINGS

### 8 Placards and Markings

The following limitation placards must be placed in plain view on the aircraft.  
Near the airspeed indicator a placard will state the following:

Maneuvering speed  $V_A = 93$  KIAS

On the right hand side of the panel a placard will state the following:

#### **Passenger Warning**

This aircraft was manufactured in accordance with Light Sport aircraft airworthiness standards and does not conform to standard category airworthiness requirements.

Near baggage compartment a placard will state the following:

Fasten tie-down net  
Maximum weight 44 lbs

On the doors there are the following placards:

LIGHT SPORT

For other placards see Maintenance Manual

Feedback Form

Send your comments to:

In the USA:

Tecnam Aircraft, Inc.

1350 Churchill Way

Marietta, GA 30062

[www.tecnamaircraft.com](http://www.tecnamaircraft.com)

Tecnam@bellsouth.net

(770) 309-4155



Italian Address:

COSTRUZIONI AERONAUTICHE TECNAM s.r.l.  [www.tecnam.com](http://www.tecnam.com)

Casoria industrial plant

1a Traversa via G. Pascoli n°1



80026 Casoria (NA) – ITALY

 +39 081 7583210  +39 081 7584528

Capua industrial plant

Via Maiorise

81043 Capua (CE) - ITALY

 +39 0823 620134  +39 0823 622899